

Zeeco

A SUBDIVISION OF PART OF THE SOUTHEAST QUARTER (SE/4) OF SECTION 17, TOWNSHIP 18 NORTH, RANGE 15 EAST, CITY OF BROKEN ARROW, WAGONER COUNTY, OKLAHOMA.

PLAT No.
PLC5-401A

2008-2781 Book: 1737 pg: 401
2/27/2008 11:27 AM pgs: 401 - 401
Fees: \$84.00 Doc: \$0.00
Carolyn M. Kusler, County Clerk
Wagoner County - State of Oklahoma

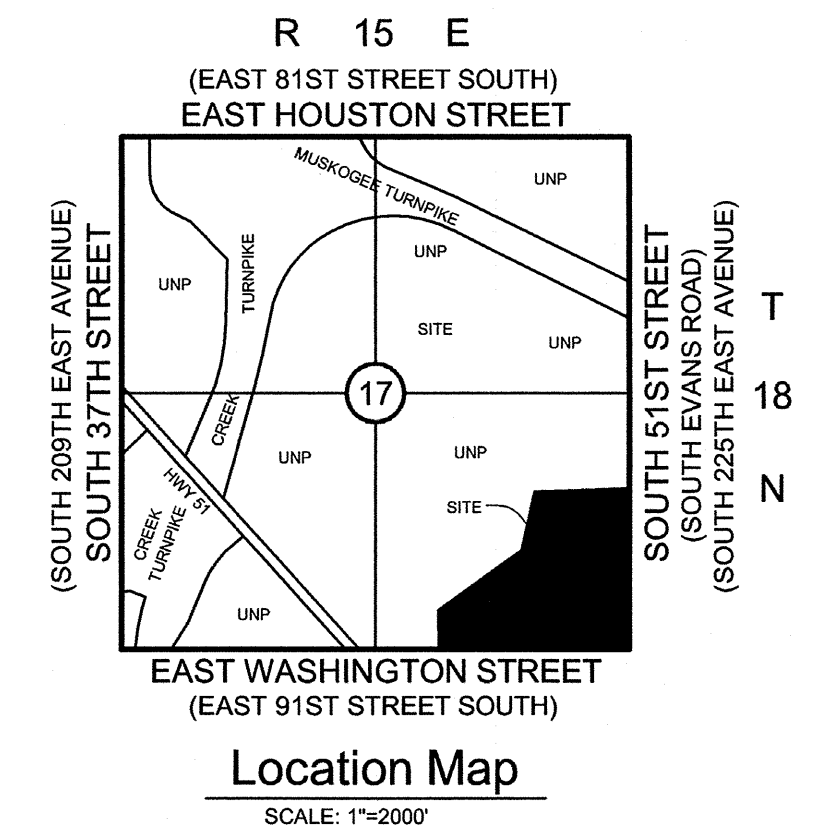
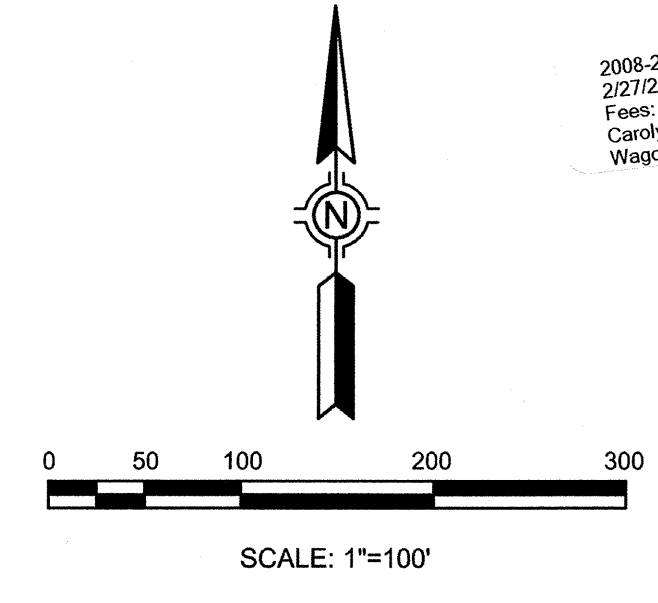

Owner:
Zink Wagoner Real Estate, LLC
An Oklahoma Limited Liability Company
22151 E. 91st Street
Broken Arrow, Oklahoma 74014
Phone: (918) 258-8551
Contact: Mr. Tom Butchko

Engineer/Surveyor:
Sisemore Weisz & Associates, Inc.
Certificate of Authorization No. 2421 Exp. June 30, 2009
6111 E. 32nd Place
Tulsa, Oklahoma 74135
Phone: (918) 665-3600
E-mail: gweisz@sw-assoc.com

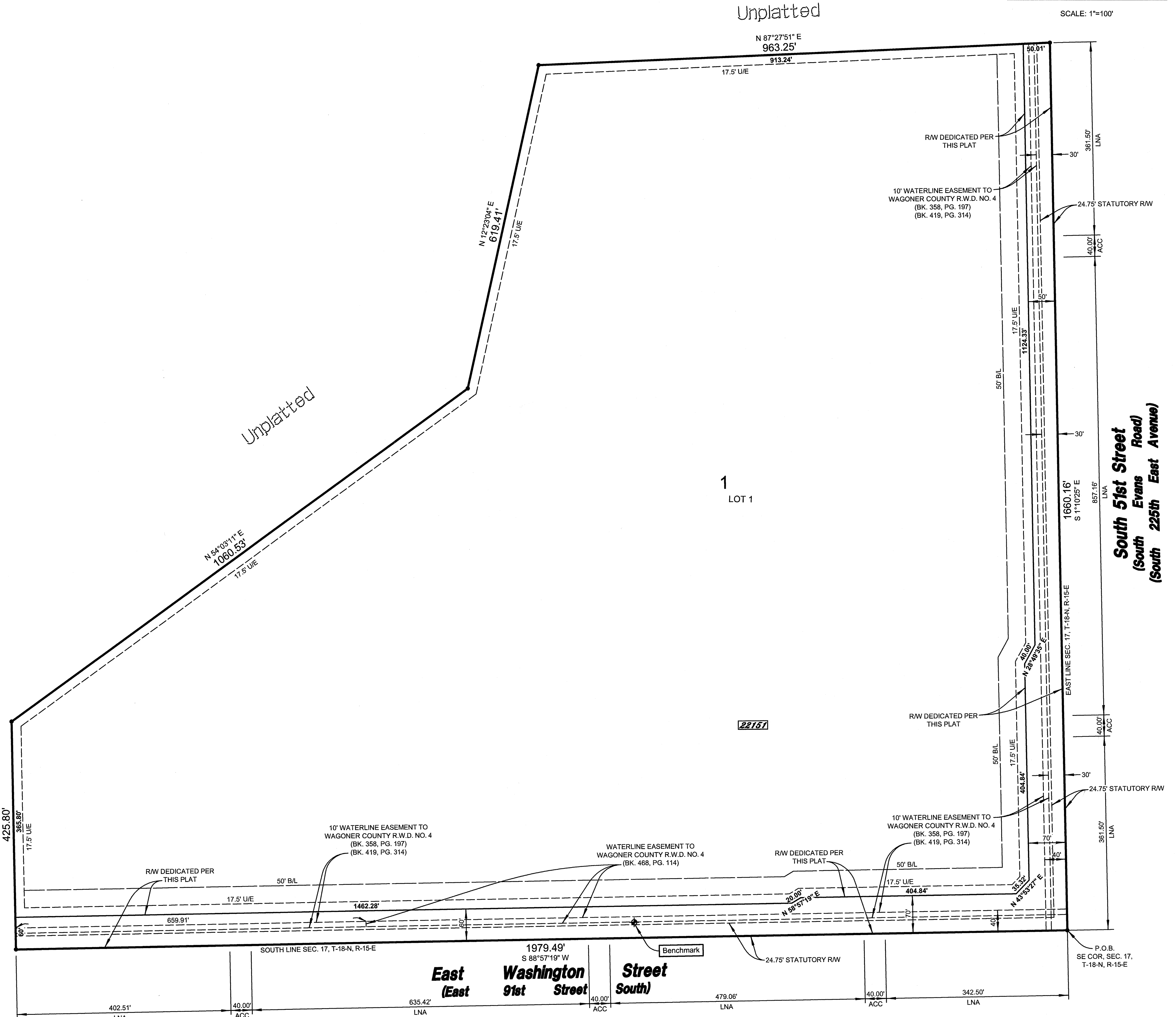

Subdivision Statistics:
SUBDIVISION CONTAINS ONE (1) LOT IN ONE (1) BLOCK
SUBDIVISION CONTAINS 55.454 TOTAL ACRES (2,415,581 SF)
LOT ONE (1), BLOCK ONE (1) CONTAINS 50.574 TOTAL ACRES (2,202,996 SF)
R/W BEING DEDICATED BY PLAT CONTAINS 4.880 ACRES (212,585 SF)

Legend:
U/E = UTILITY EASEMENT
B/L = BUILDING SETBACK LINE
R.W.D. = RURAL WATER DISTRICT
R/W = RIGHT-OF-WAY
ACC = ACCESS
LNA = LIMITS OF NO ACCESS
P.O.B. = POINT OF BEGINNING
22151 = STREET ADDRESS

Monumentation:
3/8" IRON PINS TO BE SET AT ALL PROPERTY CORNERS.

Basis of Bearing:
THE BEARING BASE FOR THIS PLAT IS BASED UPON THE EAST LINE LINE OF THE SE/4 OF SEC. 17, T-18-N, R-15-E BEING S 1°10'25" E.

Benchmark:
3/8" IRON PIN LOCATED APPROXIMATELY 814' WEST OF THE SOUTHEAST CORNER OF SECTION 17, T-18-N, R-15-E. NGVD 1929 DATUM ELEVATION=720.98

Notes:
1. ADDRESS SHOWN ON THIS PLAT WAS ACCURATE AT THE TIME THIS PLAT WAS FILED. ADDRESS IS SUBJECT TO CHANGE AND SHOULD NEVER BE RELIED ON IN PLACE OF LEGAL DESCRIPTION.
2. STORMWATER DETENTION ACCOMMODATIONS FOR THIS SITE ARE PROVIDED IN ACCORDANCE WITH FEE-IN-LIEU OF DETENTION DETERMINATION #DD-60706-31.

STATE OF OKLAHOMA)
COUNTY OF WAGONER) SS

I, _____, Wagoner County Clerk, in and for the County and State above named, do hereby certify that the foregoing is a true and correct copy of a like instrument now on file in my office.

Dated the ___ day of _____, 20__

Deputy



CERTIFICATE

I hereby certify that all real estate taxes involved in this plat have been paid as reflected by the current tax rolls. Security as required has been provided in the amount of \$4,323.88 per trust receipt no. 5 to be applied to 2008 taxes. This certificate is NOT to be construed as payment of 2008 taxes in full but is given in order that this plat may be filed on record 2008 taxes may exceed the amount of the security deposit.

Dated 2-27-08

Wagoner County Treasurer
By: _____
Deputy



Certified True Copy
CAROLYN KUSLER, COUNTY CLERK
Wagoner County, Okla.
By: _____
Deputy

APPROVED 12-17-07 by the City Council of the City of Broken Arrow, Oklahoma.

Mayor
Attest: _____
City Clerk
2-19-08