

ORIGINAL



BROKEN ARROW

Where opportunity lives

**PROPOSAL AND CONTRACT
DOCUMENTS FOR**

Nuisance Abatement - Structural Securing Contract

**CONTRACT NO. 24XXXX
BID NO. 24.115**

BROKEN ARROW CITY COUNCIL

**Debra Wimpee, Mayor
Christi Gillespie, Vice Mayor
Johnnie Parks, Member
Lisa Ford, Member
Justin Green, Member**

**Michael L. Spurgeon., City Manager
Ethan J.L. Edwards, P.E., Director of Engineering and Construction
Joe Williford, Chief Building Inspector**

CONTRACT NO. 24XXXX
TABLE OF CONTENTS

I. BIDDING REQUIREMENTS AND INSTRUCTIONS

Notice and Invitation to Bidders	4
Requirements for Bidding and Instructions to Bidders	7

II. PROPOSAL DOCUMENTS

Proposal	16
Non-Interest Affidavit	20
Affidavit of Non-Boycotting of Energy Companies	21
Non-Collusion Affidavit	22
Certificate Regarding Debarment, Suspension and other Responsibility Matters	23
Statement of Qualifications and Experience	24

III. SURETY BONDS

Statutory Bond	26
Performance Bond	27
Maintenance Bond	28

IV. STANDARD CONTRACT TERMS AND CONDITIONS FOR PUBLIC CONSTRUCTION CONTRACTS

1.0	Definitions	30
2.0	Scope	33
3.0	Contract Administrator's Power and Duties	34
4.0	Time for Completion	35
5.0	Liquidated Damages	36
6.0	Contractor's Duties and Responsibilities Regarding the Work	36
7.0	Contractor's Obligation and Risk	44
8.0	Contractor to Check Drawings and Schedules	45
9.0	Drawings Furnished by Contractor	45
10.0	Patent Rights	45
11.0	Modification and Alterations	45
12.0	Suspension of Work on Notice	46
13.0	City's Right to Terminate Contract	46
14.0	Contractors' Right of Protest	47
15.0	Extra Work	47
16.0	Supervision and Inspection	49
17.0	Control of Materials	49
18.0	Legal Duties and Responsibilities to the Public	50
19.0	Contractor Is Independent Contractor	51
20.0	Contractor and His Employees	51
21.0	Assignment and Subletting of Contract	51
22.0	Indemnification and Defense of Suits	52
23.0	Worker's Compensation, Employer's Liability Insurance, Owner's Risk and Liability Insurance and Property Insurance Requirements	53
24.0	Minimum Insurance Amounts	53
25.0	Method and Basis of Payment for Items of Work	54

26.0	Administrative Costs and Fees	56
27.0	Payments	56
28.0	Release of Liability and Acceptance	57
29.0	Payment or Acceptance Not a Waiver by City	57
30.0	Contractor's Obligation after Acceptance	57
31.0	Contractor's Warranties and Guaranties	58
32.0	Laws and Ordinances	58
33.0	Immigration Compliance	58
34.0	Notices	59
35.0	Sections and Paragraph Captions	59
36.0	Contract Binding on the Parties	59

V. GENERAL SPECIFICATIONS

Division I	Control of Equipment	62
Division II	Construction Specifications	63
Division III	Material Specifications	64
Division IV	Special Provisions	65

VI. BOARD UP PROCEDURES (US FIRE ADMINISTRATION) 67

**SECTION I.
BID REQUIREMENTS
AND INSTRUCTIONS**

NOTICE AND INVITATION TO BIDDERS
CONTRACT NO. 24XXXX
QUESTCDN PROJECT NO. 8759857
BID NO. 24.115

Notice is hereby given that the City of Broken Arrow, Oklahoma is accepting Bids on the following Work:

Nuisance Abatement - Structural Securing Contract: This contract is for the mowing and trimming of private and/or public lots; the removal and disposal of ALL trash, debris, tires, appliances, fluids, etc.; the securing of structures; tree and brush removal; clearing of property; trenching, construction of earthen barriers, fences, backfilling, draining swimming pools and other sources of stagnant water entrapment on private and/or public land as needed.

The work under this contract shall be performed within the corporate limits of the City of Broken Arrow or upon other properties that might be owned by the City, at the unit price bid for each work item completed. The work will be accomplished by the issuance of individual work orders which will define the property or properties and work items to be performed. This contract will be for one year (i.e., 365days) from date of award., with two (2) optional one (1) year (356 day) extensions. Upon mutual agreement by the City and the CONTRACTOR, this contract may be renewed for another year, up to two total renewals, with up to a three percent (3%) increase in unit prices per year.

There will be an optional pre bid meeting on October 17, 2023 from 10:00 AM. This meeting will be held virtually. The link for the pre bid meeting can be found by opening the link below, then opening up the correct project under “Current Bid Opportunities”:

<https://www.brokenarrowok.gov/business/bids-contracts>

Contract No: 24XXXX

Complete digital project documents are available at

https://qap.questcdn.com/qap/projects/prj_browse/ipp_browse_grid.html?projType=all&provider=7011687&group=7011687

or by “control clicking” on the following link:

[Broken Arrow, City of - Projects](#)

and/or www.questcdn.com. A contractor may view the project documents at no cost prior to becoming a Planholder. Input the QuestCDN project number 8759857 on the website’s projects search page to download the digital project documents for \$22. Contact QuestCDN Customer Support at 952-233-1632 or info@questcdn.com for assistance in membership registration, downloading digital project information and vBid online bid submittal questions. Project bid documents must be downloaded from QuestCDN which will add your company to the Planholder List and allow access to vBid online bidding for the submittal of your bid (which is required for this project). Bidders will be charged a fee of \$42 to submit a bid electronically.

FOR THIS PROJECT, BIDS WILL ONLY BE RECEIVED AND ACCEPTED VIA THE ONLINE ELECTRONIC BID SERVICE THROUGH QUESTCDN.COM. All required affidavits and Proposal Guarantees MUST be submitted through QuestCDN.com with bid documents. Only bids submitted as required above by 1:45 p.m. on the date of the bid opening

will be considered.

Sworn statement of the Bidder's assets and liabilities, technical qualifications and performance in the form of the latest annual report and financial statement are not required to be submitted with the Bidder's Proposal, but City of Broken Arrow may require such statements prior to award of the construction contract. The References, using the forms found in Section II Proposal Documents, must be submitted with the bid and include, as a minimum, the information required herein. Failure to submit the information required in these documents may result in the City of Broken Arrow considering the Bid non-responsive and result in rejection of the Bid by the City of Broken Arrow. Bidders may be required to provide supplemental information if requested by the City of Broken Arrow to clarify, enhance or supplement the information provided in the References.

The apparent successful Bidder shall, within two (2) days after Bid opening, submit to The City a list of the Suppliers, individuals or entities proposed for the following portions of the Work: the mowing and trimming of private and/or public lots; the removal and disposal of ALL trash, debris, tires, appliances, fluids, etc.; the securing of structures; tree and brush removal; clearing of property; trenching, construction of earthen barriers, fences, backfilling, draining swimming pools and other sources of stagnant water entrapment on private and/or public land as needed.. Such list shall be accompanied by a Statement of Qualifications, using the forms found in Section II Proposal Documents, with pertinent information regarding similar projects and other evidence of qualification and experience for each such Subcontractor, Supplier, or other individual or entity. If The City or Engineer, after due investigation, has reasonable objection to any proposed Subcontractor, Supplier, individual, or entity, The City may, before the Notice of Award is given, request apparent successful Bidder to submit an acceptable substitute, within one (1) day of notification. If apparent Successful Bidder declines to make any such substitution, The City may award the Contract to the next lowest Bidder that proposes to use acceptable Subcontractors, Suppliers, or other individuals or entities. In such event, the next lowest Bidder shall, within two (2) days after requested by The City, submit to The City the above required list of the Subcontractors, Suppliers, and other individuals or entities.

In evaluating whether a Bidder is responsible, City of Broken Arrow will consider the qualifications and experience of the Bidder and may consider the qualifications and experience of Subcontractors and Suppliers proposed for those portions of the Work for which the identity of Subcontractors and Suppliers must be submitted as provided above.

As a Proposal Guarantee, a certified check, cashier's check, bid bond or irrevocable letter of credit issued by an insured financial institution as required by law must accompany each Proposal for an amount equal to five percent (5%) of the total Bid made payable, without reserve, to the City of Broken Arrow. The successful Bidder must, within ten (10) days after receiving notice of award, furnish a Performance Bond, Statutory Bond and Maintenance Bond in the forms prescribed by City of Broken Arrow in the amounts equal to the Contract price.

BIDS WILL BE OPENED publicly at 2:00 p.m. on November 7, 2023,

at <http://www.brokenarrowok.gov/business/bids-contracts/virtual-bid-openings>

or by "control clicking" on the following link:

[Virtual bid openings | Broken Arrow, OK.](#)

Due to social distancing requirements of the COVID-19 health crisis, bidders and other members of the public may attend and view the bid opening only through the following online access:

<http://www.brokenarrowok.gov/business/bids-contracts/virtual-bid-openings>

or by “control clicking” on the following link:

[Virtual bid openings | Broken Arrow, OK.](#)

The bid opening will be live-streamed and recorded.

The acceptance and award of this Bid will be considered by the Broken Arrow City Council. The City of Broken Arrow reserves the right to reject any or all Bids. Project will be awarded to the responsible Bidder with the lowest base bid or lowest combined base and additive alternate bids, if any, which is most advantageous to City of Broken Arrow. Applicable additive alternates, if any, will be determined at the City of Broken Arrow’s discretion. The lowest responsible Bidder will be notified within ten (10) working days of the Bid opening as to when this Public Construction Contract will be placed on the Broken Arrow City Council Agenda for consideration.

Ethan J.L. Edwards

10/5/2023

Ethan J.L. Edwards, P.E.

Director of Engineering and Construction

Advertise: October 10, 2023
October 17, 2023

**REQUIREMENTS FOR BIDDING AND
INSTRUCTIONS TO BIDDERS
CONTRACT NO. 24XXXX
QUESTCDN PROJECT NO. 8759857
BID NO. 24.115**

Notice is hereby given that the City of Broken Arrow, Oklahoma is accepting Bids on the following Work:

Nuisance Abatement - Structural Securing Contract: This contract is for the mowing and trimming of private and/or public lots; the removal and disposal of ALL trash, debris, tires, appliances, fluids, etc.; the securing of structures; tree and brush removal; clearing of property; trenching, construction of earthen barriers, fences, backfilling, draining swimming pools and other sources of stagnant water entrapment on private and/or public land as needed.

The work under this contract shall be performed within the corporate limits of the City of Broken Arrow or upon other properties that might be owned by the City, at the unit price bid for each work item completed. The work will be accomplished by the issuance of individual work orders which will define the property or properties and work items to be performed. This contract will be for one year (i.e., 365days) from date of award., with two (2) optional one (1) year (356 day) extensions. Upon mutual agreement by the City and the CONTRACTOR, this contract may be renewed for another year, up to two total renewals, with up to a three percent (3%) increase in unit prices per year.

There will be an optional pre bid meeting on October 17, 2023 from 10:00 AM. This meeting will be held virtually. The link for the pre bid meeting can be found by opening the link below, then opening up the correct project under “Current Bid Opportunities”:

<https://www.brokenarrowok.gov/business/bids-contracts>

Contract No: 24XXXX

Complete digital project documents are available at

https://gap.questcdn.com/gap/projects/prj_browse/ipp_browse_grid.html?projType=all&provider=7011687&group=7011687

or by “control clicking” on the following link:

[Broken Arrow, City of - Projects](#)

and/or www.questcdn.com. A contractor may view the project documents at no cost prior to becoming a Planholder. Input the QuestCDN project number 8759857 on the website’s projects search page to download the digital project documents for \$22. Contact QuestCDN Customer Support at 952-233-1632 or info@questcdn.com for assistance in membership registration, downloading digital project information and vBid online bid submittal questions. Project bid documents must be downloaded from QuestCDN which will add your company to the Planholder List and allow access to vBid online bidding for the submittal of your bid (which is required for this project). Bidders will be charged a fee of \$42 to submit a bid electronically.

FOR THIS PROJECT, BIDS WILL ONLY BE RECEIVED AND ACCEPTED VIA THE ONLINE ELECTRONIC BID SERVICE THROUGH QUESTCDN.COM. All required

affidavits and Proposal Guarantees MUST be submitted through QuestCDN.com with bid documents. Only bids submitted as required above by 1:45 p.m. on the date of the bid opening will be considered.

THE CITY OF BROKEN ARROW RESERVES THE RIGHT TO REJECT ANY OR ALL BIDS. The City of Broken Arrow reserves the right to select the Proposal, the award of which will, in City's judgment, best secure the efficient and due performance of the Work, after considering the responsibility of the Bidders and the amounts of their Bids. Contracts will be awarded only to qualified Bidders capable of performing the classes of Work required.

Bids in which the prices are obviously unbalanced may be rejected. Proposals that are incomplete, obscure or contain additions not called for, erasures, alterations or irregularities of any kind may be rejected as informal.

Until the final award of the Contract, the City of Broken Arrow reserves the right to reject any or all Proposals and to waive technical errors and/or informalities at its sole discretion, as may be deemed to be for the best interests of the City. Whether the failure to comply with any bid requirement is a technical error or informality is at the sole discretion of the City.

BIDS WILL BE OPENED publicly at 2:00 p.m. on November 7, 2023,

at <http://www.brokenarrowok.gov/business/bids-contracts/virtual-bid-openings>

or by "control clicking" on the following link:

[Virtual bid openings | Broken Arrow, OK.](#)

Due to social distancing requirements of the COVID-19 health crisis, bidders and other members of the public may attend and view the bid opening only through the following online access:

<http://www.brokenarrowok.gov/business/bids-contracts/virtual-bid-openings>

or by "control clicking" on the following link:

[Virtual bid openings | Broken Arrow, OK.](#)

The bid opening will be live-streamed and recorded.

Each Bidder is required to state in their proposal, their full name and address and the names of all persons and/or entities interested with them. If made by a partnership, the name and post office address of each partner must be shown. If made by a corporation, the Proposal must show the name of the state under the laws of which the corporation was incorporated and the name and title of the officer or officers with authority to sign the Contract. If made by a limited liability company, the Proposal must show the name of the member or members with authority to sign the Contract. A Proposal signed by an agent must be accompanied by satisfactory evidence of his authority to sign such Proposal on behalf of the Bidder. No Bid will be considered if made in collusion with any other Bidder. The Bidder shall sign their Proposal.

More than one Bid from an individual, partnership or business entity, whether under the same or different names, will not be considered. Reasonable grounds for believing that any Bidder is interested in more than one Bid for the Work will cause rejection of all Bids submitted by such

Bidder. The Bidder shall execute a non-interest and non-collusion affidavit which shall be submitted with and as a part of the Bid.

Bids shall be made upon each item of the Work with reasonable relation to the probable cost of doing the Work included in such item. The unit price bid must cover all expense for furnishing the labor, materials, tools, equipment, and apparatus of every description to construct, erect, and furnish all work required by and in conformance with the Drawings and Specifications. The right is reserved to reject wholly any Bid in the case the items thereof are grossly unbalanced or appear to the City to be so unbalanced as to adversely affect or to likely adversely affect the best interests of the City. No partial Bids will be considered and permission will not be given for the withdrawal of any Bid after the Bid opening.

The References, using the forms found in Section II Proposal Documents, must be submitted with the bid and include, as a minimum, the information as described in this section of the Contract Documents. Failure to submit the required information in the References may result in the Owner considering the Bid non-responsive and result in rejection of the Bid by the Owner. Bidders may be required to provide supplemental information if requested by the Owner to clarify, enhance or supplement the information provided in the References.

As a Proposal Guarantee, a certified check, cashier's check, bid bond or irrevocable letter of credit issued by an insured financial institution as required by law must accompany each Proposal for an amount equal to five percent (5%) of the total Bid made payable, without reserve, to the City of Broken Arrow. A scanned copy of the Proposal Guarantee shall be uploaded at www.questcdn.com along with the Proposal. The original certified check or cashier's check shall be mailed by bidder and received by the Engineering & Construction Department within 48 hours of the bid submission deadline. Such certified or cashier's checks will be returned promptly to the Bidders after the Contract is awarded, except the check or bond deposited by the successful Bidder. Such check or bond will be promptly returned when the successful Bidder executes the Contract and furnishes the required security within the time provided. No Bid will be considered which is not accompanied by said cashier's check, certified check, irrevocable letter of credit or bond, as provided herein.

The cashier's check, certified check, irrevocable letter of credit or bond shall be deposited as a Proposal Guarantee that the Bidder, if successful, will enter into the Contract and furnish a Performance Bond, Statutory Bond and Maintenance Bond. A surety company authorized to do business in Oklahoma, having a local representative and satisfactory to the City of Broken Arrow, will be required as surety on said bonds. Failure to provide the guarantee of a surety company as surety for a Bond will be sufficient cause for rejection of the Bid.

The Contractor will be required to carry workmen's compensation and public liability insurance as required by law and by City's Standard Contract Terms and Conditions for Public Construction Contracts.

Bidder's attention is called to Title 68, O.S. § 1701, *et seq.* of the Oklahoma Statutes. This Act requires non-resident contractors and subcontractors to give written notice, by certified mail with return receipt request, to the Oklahoma Tax Commission, the Oklahoma Employment Security Commission, the State Industrial Court, and the County Assessors of each county in which such Contract Work or services is to be performed before actually commencing Work. This Act also requires the Contractor to file with the Oklahoma Tax Commission a Surety Bond with a Surety authorized to do business in Oklahoma in the penal sum of not less than ten percent (10%) of the amount of the Contract price, payable to the State of Oklahoma, conditioned upon compliance with the tax laws of Oklahoma, both state and local, the Oklahoma Employment Security Act and the Oklahoma Workmen's Compensation Law.

The apparent successful Bidder shall, within two (2) days after Bid opening, submit to City of Broken Arrow the References, using the form found in Section II Proposal Documents, with pertinent information regarding similar projects and other evidence of qualification and experience for each such Subcontractor, Supplier, or other individual or entity. If City of Broken Arrow or Engineer, after due investigation, has reasonable objection to any proposed Subcontractor, Supplier, individual, or entity, City of Broken Arrow may, before the Notice of Award is given, request apparent successful Bidder to submit an acceptable substitute, within one (1) day of notification, in which case apparent Successful Bidder shall submit substitute, Bidder's Bid price will be increased (or decreased) by the difference in cost occasioned by such substitution, and Owner may consider such price adjustment in evaluating Bids and making the Contract award. If apparent Successful Bidder declines to make any such substitution, City of Broken Arrow may award the Contract to the next lowest Bidder that proposes to use acceptable Subcontractors, Suppliers, or other individuals or entities. Declining to make requested substitutions will constitute grounds for forfeiture of the Bid security of any Bidder. In such event, the next lowest Bidder shall, within two (2) days after requested by the City of Broken Arrow, submit to City of Broken Arrow the above required list of the Subcontractors, Suppliers, and other individuals or entities.

Any Subcontractor, Supplier, individual, or entity so listed and against which City of Broken Arrow or Engineer makes no written objection prior to the giving of the Notice of Award will be deemed acceptable to City of Broken Arrow and Engineer unless or until the work performed by said individual or entity is deemed unacceptable by City of Broken Arrow.

In evaluating whether a Bidder is responsible, City of Broken Arrow will consider the qualifications and experience of the Bidder and may consider the qualifications and experience of Subcontractors and Suppliers proposed for those portions of the Work for which the identity of Subcontractors and Suppliers must be submitted as provided above.

The successful Bidder will be required to execute the Contract and deliver the same, together with the required bonds, within ten (10) days from the date that the notice of the award is given to the successful Bidder, either by personal delivery or by registered mail, addressed to the successful Bidder at their residence or place of business as set out in their proposal. Should the successful Bidder fail or neglect to execute the Contract, the Bid award and Contract will be deemed to have been abandoned by the successful Bidder and thereupon, the amount of the Proposal Guarantee accompanying the proposal shall be due and payable to the City of Broken Arrow as liquidated damages.

Bidders shall carefully examine the site of the proposed Work and shall inform themselves as to facilities for delivery and placing of all materials and equipment. **For questions, please contact the Engineering & Construction Department by email at engineering.construction@brokenarrowok.gov or by phone at (918)259-7000 x5414.** No assertions by the Contractor for lack of knowledge of the existing conditions of the property or difficulties encountered in executing the Work as a result of a failure to inspect the property or site will be accepted as an excuse for any failures or omissions to fulfill all of the Contract requirements or as a basis for a claim for compensation for Extra Work. The Bidder is required to read, examine and acquaint themselves with the Proposal, Plans and Specifications, and Standard Contract Provisions for the Work contemplated. The Bidder, in submitting a proposal, warrants that the Bidder has investigated and is acquainted with the conditions to be encountered in performing the Work, including the character, quality and quantities of Work to be performed and the requirements of the Contract. Submission of a Bid shall be considered conclusive evidence that the Bidder has made such examinations and is fully aware of all the conditions pertaining to the site, Work and Contract Documents.

The Bidder's attention is directed to the Standard Contract Terms and Conditions concerning discrimination.

A Bidder may withdraw the Bidder's Proposal through www.questcdn.com at any time prior to the bid submission deadline.

Proposals will be opened, read and viewed publicly as provided above. After the Proposals are opened and read, the totals will be compared and the results of such comparison will be immediately made public. Errors in extensions of unit prices or incomplete extensions thereof may result in the rejection of a Proposal. Conditional bids will not be accepted.

The Award of the Contract, if it be awarded, will be to the lowest responsible Bidder whose Bid complies with all the requirements prescribed, exclusive of technicalities and/or informalities waived. The award will be made within thirty (30) days after the date of opening the Proposals. When the Notice to Bidders permits Bidders to Bid in the alternative on any one, or upon any two or more of a group of Public Construction Projects, the Contract or Contracts for the Work of those Public Construction Projects will be awarded pursuant to the Bid or the combination of Bids, which will, in City's judgment, best secure the efficient and due performance of the Work, after considering the responsibility of the Bidders and the amounts of their Bids.

The successful Bidder must, within ten (10) days after receiving notice of the award, furnish a Performance Bond, Statutory Bond and Maintenance Bond in the forms prescribed by the City of Broken Arrow in the amounts equal to the Contract price. The Contractor shall maintain these Bonds until final payment is made under the Contract and in the event of insolvency of the Surety, the Contractor shall forthwith furnish and maintain other Surety satisfactory to the City of Broken Arrow. One (1) copy of each of the Statutory Bond must be filed with the City Clerk for the City of Broken Arrow. The Maintenance Bond shall guarantee the Work done under the Public Construction Contract for a period of one (1) year after final acceptance by the City of Broken Arrow against defects in materials or workmanship.

The condition of the Sureties' obligations under this Contract is that if the Contractor shall well and truly keep and perform each and all of the obligations delegated to Contractor herein, including, without limitations by specification, the maintenance of the work for the period stated herein above, then after completion in the manner thereafter provided, the Sureties' obligations shall be null and void. Otherwise, should Contractor fail to perform as fully set out herein the Sureties' obligations shall remain in full force and effect.

The condition of the Sureties' obligations under this Contract is that they shall be liable to the City of Broken Arrow in a direct action, either with or without said Contractor as a part, for any failure of said Contractor to discharge, carry out and perform every promise, covenant, obligation, condition, term or provision herein to be kept or performed by the said Contractor and that Sureties agree to respond to the City of Broken Arrow for all damages sustained by it for reason of any such failure. In the event of default by Contractor, Sureties may fulfill the obligations hereunder by completing the Work pursuant to the terms herein.

The condition of the Sureties' obligations are that no change, extension of time, alteration or addition to the terms of the Contract or to the Work to be performed hereunder shall in any way affect the obligation of the Sureties, and the Sureties waive notice of any such change, extension of time, alteration or addition to the terms of this Contract or to the Work or Specifications.

The successful Bidder will be required to execute the Contract within ten (10) days from the date that the Notice of Award is given to the Bidder by personal delivery or by registered mail addressed to the same at the residence or place of business address as stated in the Bid. No Bid shall be considered binding on the City of Broken Arrow until the Contract is executed by both parties.

Failure by the successful Bidder to execute the Contract and to file the required Bonds shall be just cause for the annulment of the award and the forfeiture of the Proposal Guaranty to the City of Broken Arrow, not as a penalty but as liquidated damages. In such event, such Bidder will not and cannot be considered the lowest responsible Bidder and an award may then be made among the remaining Bidders, to the lowest responsible Bidder of the remaining Bidders; or the Public Construction Contract for the Work may be re-advertised, as the City of Broken Arrow may decide.

Coordination of drawings and specifications: Project Drawings, Technical Specifications, and all supplementary documents are essential parts of the Contract and a requirement in one is as binding as if in all. The City intends them to be complementary and to describe a complete Contract. In case of discrepancy between Contract documents, the order of precedence is as follows: (1) For Information, Technical Specifications over Drawings; (2) For Dimensions, Project Drawings over Specifications. Project Drawings and Specifications both take precedence over supplementary documents.

The City of Broken Arrow shall return a fully executed copy of agreement within fourteen (14) days after its execution. The City of Broken Arrow proposes to begin actual work within ten (10) days of notification to proceed. Contract time for project shall be Three Hundred Sixty Five (365) calendar days. Liquidated damages for this Contract are the sum of One Thousand dollars and no cents (\$1,000.00) per day for each day the Contractor exceeds the Contract time for completion. This amount is fixed and agreed upon because of the impracticability and extreme difficulty of fixing and ascertaining the actual damages sustained by the City of Broken Arrow in such event.

The City of Broken Arrow is exempt from the payment of sales taxes or use taxes, and pursuant to Title 68 O.S. Section 1356(10), direct vendors to the City of Broken Arrow are also exempt from those taxes. A bidder may exclude from his bid appropriate sales taxes which he will not have to pay while acting for and on behalf of the City of Broken Arrow. See the City of Broken Arrow Standard Contract Terms and Conditions for Public Construction Contracts.

CITY OF BROKEN ARROW, OKLAHOMA

By: Ethan J.L. Edwards 10/5/2023
Ethan J.L. Edwards, P.E.
Director of Engineering and Construction

Bidder to satisfactorily and without delay, carry out the performance of the Contract. Such showing may (but need not) be made, in whole or in part, by letters of credit. Each Bidder may further be required to submit on the same form a sworn statement of his technical qualifications and performance record. These statements shall be submitted with the Bidder's Proposal and shall be in the form of the latest annual report and financial statement. The City of Broken Arrow may reject any Bid, which is not accompanied by said questionnaire. Requirements for said statements will be presented in the Notice to Bidders.

Before the Contract is awarded, the Bidder may be required to furnish a complete statement of the origin, composition and manufacturer of any or all materials to be used in the construction of the Work, together with samples, which samples may be subjected to the tests provided for in the Specifications.

All workmanship shall be of the best procurable kind, both as to material and labor, in accordance with the plans and specifications on file with the Engineering and Construction Department.

Payment for the Work will be made by voucher upon estimates furnished to the City of Broken Arrow.

Written Change Orders shall be issued for all necessary changes in the Work. No work shall be done without a fully executed Change Order and such Change Orders shall be made a part of the Project file and be available for audit.

Each Bidder's Proposal or Proposals, submitted electronically through QuestCDN, for each Construction Project, for each group of Construction Projects for which Bids are to be opened simultaneously, and which (pursuant to the applicable Notice to Bidders) may be Bid upon jointly, shall be placed together, with all required documents in the Bid Proposal package. The Bidder's latest annual report and most current financial statement shall be provided if requested by the City after bids are opened but prior to contract award and so marked as to indicate the identity of the Work being Bid upon and shall include the name and address of the Bidder. Proposals will be received in the Office of the Director of Engineering and Construction until the hour and date specified in the Notice to Bidders.

Anyone contemplating submitting a Bid for the proposed Work who is in doubt as to the true meaning of any part of the Plans and Specifications or other Contract Documents or should anything be omitted from the Plans and Specifications and Drawings, which is necessary for a clear understanding of the Work or it appears that various instructions are conflicting, then the Bidder should request, in writing, written instructions to clarify such omissions or discrepancies to the Engineering & Construction Department by email at engineering.construction@brokenarrowok.gov or by phone at (918)259-7000 x5414, no later than seven (7) calendar days prior to opening Bids. **Requests for substitution of materials or equipment which require pre-approval must be submitted, along with all necessary signed and sealed plans for said substitutions, to the Engineering & Construction Department by email at engineering.construction@brokenarrowok.gov or by phone at (918)259-7000 x5414 no later than ten (10) calendar days prior to the bid opening date.** The party submitting such request shall be responsible for its prompt delivery. An interpretation of the Contract Documents will be made only by Addendum duly issued and copy of such Addendum will be delivered through QuestCDN to each party that received a set of the Contract Documents. The City of Broken Arrow will not be responsible for any other interpretation of the Contract Documents.

The successful Bidder will not receive any direct payment for providing plant, tools and equipment; furnishing, erecting, maintaining and removing the construction plant, construction roads, camps, sanitary conveniences, temporary water supply, trestles, de-watering and other temporary works; furnishing insurance, Bonds, Drawings, records, payment of fees, defense of suits; and any and all incidental requirements, whether or not they are enumerated in this paragraph. Compensation for the above listed items shall be considered included in the Proposal amounts stipulated for the Bid items, the payment for which shall constitute the total compensation due the successful Bidder for the performance of this Contract.

The site and/or Rights-of-Way where the Work is to be performed are shown on the Plans and Specifications. The Bidder, in submitting a Bid, warrants that the site or Rights-of-Way provided by the City of Broken Arrow are adequate for the performance of the Work. If any additional working area is required, the Contractor shall, at his own expense, arrange for such working area. The City of Broken Arrow shall not be liable for additional compensation as a result of any delay in obtaining Rights-of-Way. Any working area used by the Contractor shall be left in a condition satisfactory to the Contract Administrator prior to payment of the final estimate.

It is the obligation of the Bidder to make an investigation of sub-surface conditions prior to submitting a Bid. The Bidder may examine, at the office of Engineering and Construction, the records, which may or may not be shown on the Plans. Boring, test excavations, and other sub-surface investigations are not warranted to show the actual sub-surface conditions. The Bidder agrees that the Bidder will make no claims against the City of Broken Arrow; if, in carrying out the Work, the Bidder finds that the actual conditions encountered do not conform to those surface investigations. The estimated quantities shown on the Plans or in the Proposal Form, whether or not based on boring, test excavations and other sub-surface investigations, are in no way warranted to indicate the true quantities or distribution of quantities. The Bidder agrees that the Bidder will make no claim against the City of Broken Arrow if the actual quantities do not conform to the estimated quantities.

If the Work is let on the basis of a lump-sum Contract or if the estimated quantities of the Work or the lump-sum items of the Work are only approximate, although the result of calculations, the Bidder must obtain and be responsible for the data upon which the Bidder bases their Bid. The Bidder shall not be entitled to any additional compensation in case the quantities of Work actually done to fulfill the Contract and complete the Work are different from the estimated quantities.

The quantities listed in the Proposal submitted electronically through QuestCDN are to be considered approximate and are to be used only for the comparison of Bids and as basis for computing amount of security or penal sums of bonds to be furnished. The unit and lump sum process to be tendered by the Bidders are to be for the scheduled quantities as they may be increased or decreased. Payments, except for lump sum contracts and lump sum items in unit-price contracts, will be made to the Contractor only for the actual quantities of Work performed and materials furnished and may each be increased or diminished as hereinafter provided without in any way invalidating the unit and lump sum prices set forth in the Proposal and embodied in the Contract.

All Bidders must understand that the Work shall be completed in strict accordance with the Standard Contract Terms and Conditions, Plans and Specifications as interpreted by the Engineer. Interested Bidders should thoroughly examine the form of the Contract and all Contract Documents that pertain to the Work.

Before the Contract is awarded, any Bidder may be required to show, to the satisfaction of the City of Broken Arrow, that the Bidder has or can obtain the necessary and proper equipment,

tools, facilities and means and that the Bidder has the experience, ability and financial resources to perform the Contract within the time specified and in a satisfactory manner and have a satisfactory plan of operation for carrying out the terms of the Contract.

Each Bidder may be required to submit a sworn statement of the Bidder's assets and liabilities, supplemented, if the Bidder desires, with other evidence of the Bidder's possession of, or ability to procure, financial resources, which in the opinion of the City of Broken Arrow, will enable the

SECTION II.
PROPOSAL DOCUMENTS

PROPOSAL

TO: CITY COUNCIL
CITY OF BROKEN ARROW, OKLAHOMA

Note: Give the full name and address of every Bidder. Give the legal name of a corporation and the State incorporated, together with the name and address of the Corporate President and Vice President. If the Bidder is an LLC or PLLC, give the full name and address of the managing member. If Bidder is a partnership, give the full name and address of each partner.

Made by: Brian A. Homberger, Managing member
16142 State Hwy 72 Coweta OK 74429

Momentum Services LLC.
State of Oklahoma

Business Address: P.O. Box: A 327

Street Address: 1216 E. Kenosha

City: Broken Arrow State: OK. Zip: 74012

Phone Number: 918 - 951 - 1753

The undersigned Bidder has carefully examined the Plans and Specifications and other Contract Documents of the Project to be Bid, and has read the applicable "Requirements for Bidding and Instructions to Bidders"; and

Certifies that the Bidder has full knowledge of the Work specified; and

Certifies that the Bidder is the only person interested in this Proposal, has not entered into collusion with any other Bidder; and

Certifies that the Bidder will enter into the Public Construction Contract with the City to provide all necessary and proper machinery, equipment, facilities and means and to do all the Work and furnish all the material necessary to properly carry out such Contract in the manner, on the terms and under the conditions set forth therein; and

Understands that Bids shall be made by submitting complete and complying documents required, including, but not limited to, this Proposal form, a Non-Interest Affidavit, a Non-Collusion Affidavit, a Certification Regarding Debarment, Suspension, and Other Responsibility Matters, and a list of references; and

Hereby proposes to begin actual Work within ten (10) days of notification to proceed. Contract time for the project shall be One Hundred Eighty (180) calendar days.

Bidder hereby agrees to accept in full payment therefore, the amounts set out and submitted by bidder through the QuestCDN electronic proposal. The bid proposal awarded from the submitted QuestCDN electronic bid proposals will be printed and inserted in this proposal section by the City of Broken Arrow for inclusion in the contract.

THE REMAINDER OF PAGE IS BLANK

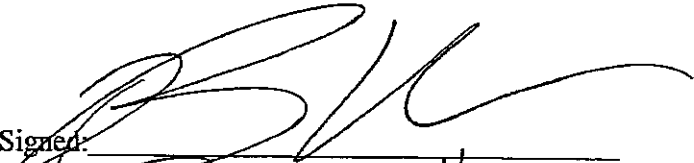
Signed: 

By: Brian A. Hamburger
Printed Name)

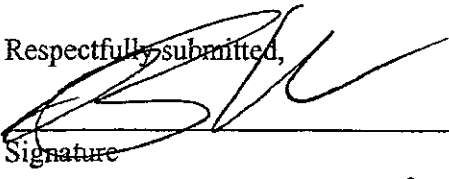
Respectfully submitted,

Signature

Momentum Services LLC.
Firm Name

Managing member
Title

1216 E. Kenosha #327
Address

83-0499219
Employer I.D. No.

Broken Arrow Ok. 74012
Address

(SEAL) – if BID is by a corporation

918-951-1753

Telephone No.

ATTEST:

11/3/23

Secretary/Witness

Date

THE REMAINDER OF PAGE IS BLANK

Itemized Bid

Line Item	Item Code	Item Description	UofM	Quantity	Unit Price	Extension
1		Lot 75'x130' or less- Handmowing	Ea	80	\$150.00	\$12,000.00
2		Lot 75'x130' or less-Brushhog	Ea	10	\$100.00	\$1,000.00
3		Lot over 75'x 130' less than 1/2 Acre	Ea	10	\$200.00	\$2,000.00
4		Lot 1/2 acre to 1 Acre w/o Trimming	Ea	10	\$150.00	\$1,500.00
5		Lot 1/2 acre to 1 Acre with Trimming	Ea	100	\$200.00	\$20,000.00
6		Acreage over 1 Acre with Trimming	SQ Acre	5	\$300.00	\$1,500.00
7		Lot 75'x130' or less -Brushhog	Ea	80	\$100.00	\$8,000.00
8		Lot over 75'x130' less than 1/2 Acre- Brushhog	Ea	10	\$150.00	\$1,500.00
9		Lot 1/2 to 1 Acre- Brushhog	Ea	10	\$150.00	\$1,500.00
10		Acreage over 1 Acre with Trimming- Brushhog	SQ Acre	10	\$300.00	\$3,000.00
11		Debris and Trash Removal	Cu Yd	1500	\$28.00	\$42,000.00
12		Tire Disposal- up to 17"	Ea	350	\$5.00	\$1,750.00
13		Tire Disposal- over 17"	Ea	250	\$5.00	\$1,250.00
14		Tire Disposal- Tractor/Equipment Tires	Ea	50	\$10.00	\$500.00
15		Each Window (0-16 SF)	Ea	250	\$60.00	\$15,000.00
16		Each Entry Door (17-32 SF)	Ea	100	\$80.00	\$8,000.00
17		Each Patio Door (33-48 SF)	Ea	20	\$80.00	\$1,600.00
18		Single Garage door (49-64 SF)	Ea	20	\$80.00	\$1,600.00
19		Double Garage door (65-112 SF)	Ea	20	\$200.00	\$4,000.00
20		Each Window (0-16 SF) High Security	Ea	125	\$80.00	\$10,000.00
21		Each Entry Door (17-32 SF) High Security	Ea	50	\$100.00	\$5,000.00
22		Each Patio Door (33-48 SF) High Security	Ea	10	\$100.00	\$1,000.00
23		Single Garage door (49-64 SF) High Security	Ea	10	\$125.00	\$1,250.00
24		Double Garage door (65-112 SF) High Security	Ea	10	\$225.00	\$2,250.00
25		2x4's for Framing	Ea	50	\$10.00	\$500.00
26		Service or Wait Calls	hr	30	\$100.00	\$3,000.00
27		Completed by Owner	Ea	10	\$100.00	\$1,000.00
28		Security Fence Installation	Ln Ft	100	\$5.00	\$500.00
29		Water Drainage pumping	hr	40	\$200.00	\$8,000.00
Base Bid Total:						\$160,200.00

Accompanying this Proposal is a ~~[certified check]~~ [cashier's check] ~~[Bid bond]~~ or ~~[irrevocable letter of credit]~~ (cross out three of four) for Eight thousand, Ten Dollars

(\$ 8010.00) payable to the City of Broken Arrow, Oklahoma, as called for in the INSTRUCTIONS TO BIDDERS and it is hereby agreed that in case of failure of the part of the undersigned to execute the Contract as aforesaid and to deliver the same and the required Bonds, executed in the form attached hereto, to the City within ten (10) days from the date that notice of the acceptance of this Proposal is given the undersigned in writing by personal delivery or in by registered mail, the undersigned will be deemed to have abandoned the Contract, and thereupon the amount of the security shall be due and payable thereunder to the City of Broken Arrow, Oklahoma, as liquidated damages for such failure and not as a forfeiture.

In case this Proposal is accepted by the City of Broken Arrow, Oklahoma, the following surety company, namely: Great American Fidelity Co. has agreed to become Surety on the Bond.

The undersigned acknowledges receipt of the following Addenda (give number and date of each):

Note: If the Proposal is made by an individual, it shall be signed with that individual's usual business signature, with the individual's business address and place of residence; if by a firm, the co-partnership name shall be signed by a member of the firm and the name and address of each member shall be given; if by a corporation, it shall be signed by a duly authorized officer, with the corporate name attested by the authorized officer subscribing his name, who shall file with the City, at the time of Bidding, a certified copy of the resolution of Directors or other proof of authority of the person subscribing such Bid to bind the corporation.

Signed: [Signature]
By: Brian A. Homburg
Printed Name)

Respectfully submitted,
[Signature]
Signature

Mountain Services LLC
Firm Name

Managing member
Title

1216 E. Kershaw #302
Address

83-0499219
Employer I.D. No.

Broken Arrow, OK. 74012
Address

(SEAL) - if BID is by a corporation

918-951-1753
Telephone No.

ATTEST:

Secretary/Witness

11/3/23
Date

(Accompany a bid bond with Attorney-in-Fact's authority from Surety)

NON-INTEREST AFFIDAVIT

State of Oklahoma)
County of Tulsa)§.

Brian A. Hombers, of lawful age, being first duly sworn, states that Affiant is the agent authorized by the Bidder to submit the attached Bid.

Affiant further states that neither the chief administrative officer nor members of the governing body of the City of Broken Arrow or their relatives within the third degree of consanguinity or affinity is interested directly or indirectly through stock ownership, partnership interest or otherwise in the subject contract. In addition, no officer or employee of the City of Broken Arrow, either directly or indirectly, owns more than a twenty-five percent (25%) interest in the Bidder's business or the stock therein or any percentage which constitutes a controlling interest.

Affiant further states that currently and within one year prior to the date of this affidavit, neither Bidder nor an officer or a director of Bidder is engaging or has engaged in a partnership, joint venture or other business relationship with the architect, engineer or other party to this Project, or one of its officers or directors, except as disclosed in full below:

The nature of such business relationship is as follows:

N/A

The names of each person having such business relationship and the position he/she holds with the respective company or firm are:

N/A

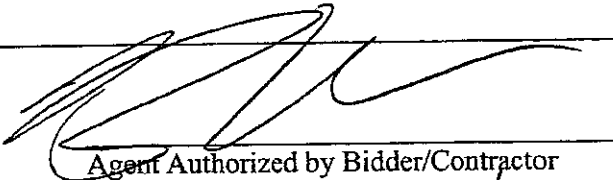

Agent Authorized by Bidder/Contractor

Brian A. Hombers / Momentum Services LLC.
Legal Name of Bidder/Contractor

Subscribed and sworn to me this 3rd day of November, 2023

My Commission Expires:

JOSELINE GONZALES
Notary Public - State of Oklahoma
Commission Number 21000891
My Commission Expires Jan 20, 2025

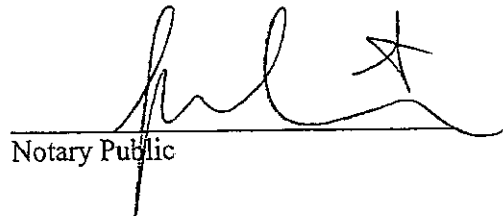
Notary Public

NON-COLLUSION AFFIDAVIT

The following affidavit is to accompany the Bid:

State of Oklahoma)
County of Tulsa)§.

Brian A. Homberger, of lawful age, being first duly sworn, states that Affiant is the agent authorized by the Bidder to submit the attached Bid for the purpose of certifying the facts pertaining to the existence of collusion among bidders and between bidders and state officials or employees, as well as facts pertaining to the giving or offering of things of value to government personnel in return for special consideration in the letting of any contract pursuant to the bid to which this affidavit is attached;

Affiant further states that he/she is fully aware of the facts and circumstances surrounding the making of the bid to which this affidavit is attached and has been personally and directly involved in the proceedings leading to the submission of such bid; and

Affiant further states that neither the Bidder nor anyone subject to the Bidder's direction or control has been a party:

- a. to any collusion among bidders in restraint of freedom of competition by agreement to bid at a fixed price or to refrain from bidding,
- b. to any collusion with any state official or employee as to quantity, quality or price in the prospective contract, or as to any other terms of such prospective contract,
- c. in any discussions between bidders and any state official concerning exchange of money or other thing of value for special consideration in the letting of a contract, nor
- d. to any collusion with any state agency or political subdivision official or employee as to create a sole-source acquisition in contradiction to Section 85.45j.1 of this title.

THE REMAINDER OF PAGE IS BLANK

NON-COLLUSION AFFIDAVIT (CONTINUED)

Affiant certifies that, if awarded the contract, whether competitively bid or not, neither the Bidder nor anyone subject to the Bidder's direction or control has paid, given or donated or agreed to pay, give or donate to any officer or employee of the City of Broken Arrow any money or other thing of value, either directly or indirectly, in procuring the contract which is the subject of this Bid.

Certified this 3rd day of November, 2023

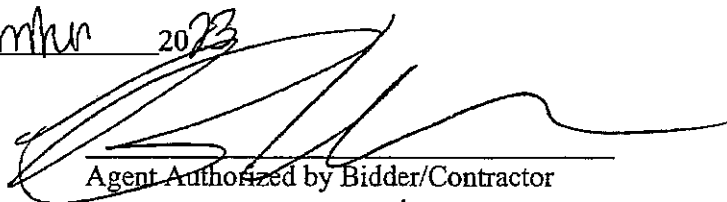

Agent Authorized by Bidder/Contractor

Brian A. Hamburg of mammoth services LLC.
Legal Name of Bidder/Contractor

Subscribed and sworn to before me this 3rd day of November, 2023

My Commission Expires:

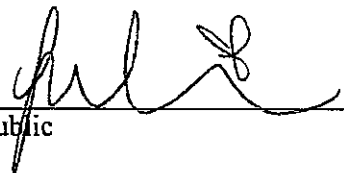
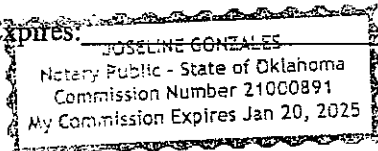

Notary Public

THE REMAINDER OF PAGE IS BLANK

**CERTIFICATION REGARDING DEBARMENT, SUSPENSION, AND OTHER
RESPONSIBILITY MATTERS**

The prospective participant certifies to the best of its knowledge and belief that it and its principals:

- (a) Are not presently debarred, suspended, proposed for debarment, declared ineligible, or voluntarily excluded from covered transactions by any Federal department or agency; and
- (b) Have not within a three-year period preceding this Proposal been convicted of or had a civil judgment rendered against them for commission of fraud or a criminal offense in connection with obtaining, attempting to obtain, or performing a public (Federal, State or local) transaction or contract under a public transaction; violation of Federal or State antitrust statutes or commission or embezzlement, theft, forgery, bribery, falsification or destruction of records, making false statements or receiving stolen property; and
- (c) Are not presently indicted for or otherwise criminally or civilly charged by a government entity (Federal, State or local) with commission of any of the offenses enumerated in paragraph (1) (b) of this certification; and
- (d) Have not within a three-year period preceding this application/Proposal had one or more public transactions (Federal, State or local) terminated for cause or default.

I understand that any false statements on this certification may be grounds for rejection of this Proposal or termination of the award. In addition, under Title 18 U.S.C.A. § 1001, *et. seq.* a false statement may result in a fine of up to \$10,000 or imprisonment for up to 5 years or both.

Brian A. Homberger managing member
Typed Name & Title of
Authorized Representative

Signature of
Authorized Representative

I am unable to certify the above statements. My explanation is attached.

STATEMENT OF QUALIFICATIONS AND EXPERIENCE

Provide a list of projects below, which demonstrates, at a minimum, successful completion of any projects each that are similar in nature and scope to this project within the last five years.

Description & Location of Project: Nuisance Abatement

Owner Name & Address: City of Tulsa

Contract Person & Phone Number: Traci Jenkins

Original Contract Time: 5/2008 - Present days Actual Construction Time: _____ days

Original Owner Budget (\$): _____ Bid Price (\$): _____

Final Actual Project Cost (\$): _____ 600 - 800K per year

Description & Location of Project: performed abatements for the last 16 years

Owner Name & Address: City of Broken Arrow

Contract Person & Phone Number: Joe Willford

Original Contract Time: 2014 to Present days Actual Construction Time: _____ days

Original Owner Budget (\$): _____ Bid Price (\$): _____

Final Actual Project Cost (\$): _____ performed abatements for the last 9 years
50K per

Description & Location of Project: Nuisance Abatements

Owner Name & Address: Tulsa County Health Dept.

Contract Person & Phone Number: Bernard Dinsley

Original Contract Time: _____ days Actual Construction Time: _____ days

Original Owner Budget (\$): _____ Bid Price (\$): _____

Final Actual Project Cost (\$): 10,000

Description & Location of Project: _____

Owner Name & Address: _____

Contract Person & Phone Number: _____

Original Contract Time: _____ days Actual Construction Time: _____ days

Original Owner Budget (\$): _____ Bid Price (\$): _____

Final Actual Project Cost (\$): _____

**SECTION III.
SURETY BONDS**

STATUTORY BOND

KNOW ALL MEN BY THESE PRESENTS, that we Momentum Services, LLC, as Principal(s) and Great American Insurance Company, a Corporation organized under the laws of the State of Ohio, and authorized to transact business in the State of Oklahoma, as Surety, are held and firmly bound unto the State of Oklahoma, in the penal sum of One Hundred Sixty Thousand Four Hundred and No/100----- dollars (\$160,400.00) lawful money of the United States, for the payment of which sum well and truly to be made, we bind ourselves, our successors and assigns, jointly and severally, firmly by these presents. Signed and sealed and delivered this 12th day of December, 20 23, in triplicate counterparts.

THE CONDITION OF THE FOREGOING OBLIGATION IS SUCH THAT WHEREAS, the said Momentum Services, LLC has on this 12th day of December, 20 23, entered into a written Contract with the City of Broken Arrow, State of Oklahoma for Nuisance Abatement - Structural Securing according to the Plans and Specifications attached to said Contract, which includes the furnishing of all necessary tools, equipment, material and labor, in accordance with the Plans and Specifications contained in said Contract and made a part thereof, which Contract, Plans and Specifications, are by reference thereto made a part of this bond. The said Surety, for value received, hereby stipulates and agrees that no change, extension of time, alteration or addition to the terms of the Contract or to the Work to be performed thereunder or the Terms and Conditions accompanying the same shall in any way affect its obligations on this Bond, and it does hereby waive notice of any such change, extension of time, alteration or addition to the Terms and Conditions of the Contract or to the Work or to the Plans and Specifications.

NOW, THEREFORE, if said Momentum Services, LLC shall pay all indebtedness incurred by the Contractor, or his Subcontractor who perform Work, in the performance of such Contract, for labor and materials and repairs to and parts for equipment used and consumed in the performance of said Contract, then this obligation shall become null and void; otherwise to be in full force and effect.

Attest:

Title

Great American Insurance Company
Surety (seal)

(Accompany this bond with Power of Attorney)

Momentum Services, LLC
Contractor Principal

By:

Title (seal)

Sharon Stone
Attorney in Fact - Sharon Stone

[Handwritten Signature]
Brian A. Homburger owner/managing member

PERFORMANCE BOND

KNOW ALL MEN BY THESE PRESENTS, that we Momentum Services, LLC, and Great American Insurance Co. with general offices in Tulsa, OK, a corporation organized under the laws of the State of Ohio and authorized to transact business in the State of Oklahoma, as Surety, and held and firmly bound unto the City of Broken Arrow, Oklahoma, a municipal corporation existing under the laws of the State of Oklahoma, in the penal sum of One Hundred Sixty Thousand Four Hundred Dollars and No/100----- dollars (\$ 160,400.00) lawful money of the United States, in payment of which sum well and truly to be made, the said Principal and Surety bind themselves, their successors and assigns, jointly and severally, firmly by these presents. Signed, sealed and delivered this 12th day of December, 2023.

WHEREAS, said Principal has entered into a written Contract with the City of Broken Arrow dated December 6, 2023, according to the Plans and Specifications attached to said Contract, which includes the furnishing of all necessary tools, equipment, materials, and labor, a copy of which Contract, together with all Plans and Specifications is hereto attached and made a part hereof as if set out in full herein; and for the payment to the City of Broken Arrow, Oklahoma, of all sums due, or which may become due, by the terms of this Contract, as well as by reason of any violation thereof by the Principal herein; and for the payment of any and all judgments, costs of suits and actions brought against the City of Broken Arrow, Oklahoma, or its officers, for any cause whatever arising from, or on account of, any injuries or damage to life or property, suffered or sustained by any person, or persons, firm, or corporation, caused by the Principal herein, its agents, servants, or employees, in the construction of said Work, or by or in consequence of, any negligence, carelessness, or misconduct, in guarding or protecting the same, or from any improper defective materials used in the construction of said Work, or any act of omission of said Principal, or its agents, servants, or employees; and for the protection of the City of Broken Arrow, Oklahoma, against all suits or claims for infringements, or alleged infringements, or patent rights or processes. The said Surety, for value received, hereby stipulates and agrees that no change, extension of time, alteration or addition to the Terms and Conditions of the Contract or to the Work to be performed thereunder or the Plans and Specifications accompanying the same shall in any way affect its obligations on this Bond, and it does hereby waive notice of any such change, extension of time, alteration or addition to the Terms and Conditions of the Contract or to the Work or to the Plan and Specifications.

NOW, THEREFORE, the said Principal has caused these presents to be executed in its name, and its corporate seal to be hereto affixed by its duly authorized officers, and the said Surety has caused these presents to be executed in its name, and its corporate seal to be hereunto affixed, by its attorney in fact, duly authorized thereunto to do so, the day and year first above written and these presents have been executed in triplicate counterparts.

Momentum Services, LLC
Contractor Principal

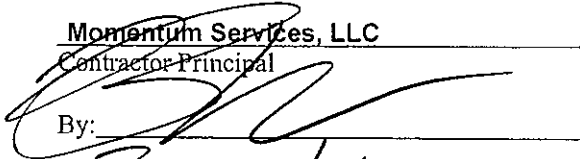
By: 

Brian A. Hamburger *owner/ managing member*
Title (seal)

Attest:

_____ Title

Great American Insurance Company
Surety (seal)

Attorney in Fact - Sharon Stone

(Accompany this bond with Power of Attorney)

MAINTENANCE BOND

Bond No.: 5407470

WHEREAS, the undersigned, Momentum Services, LLC has executed Contract No. 24XXXX, dated the 6th day of December, 20 23, designated and known as Nuisance Abatement-Structural Securing for the construction of Nuisance Abatement-Structural Securing including all of the Work mentioned and described in said Contract, and to be performed by the undersigned strictly and punctually in accordance with the Terms and Conditions and the Plans and Specifications thereof.

NOW, THEREFORE, KNOW ALL MEN BY THESE PRESENTS, that Momentum Services, LLC 1216 E. Kenosha #327, of Broken Arrow, Oklahoma as Principal, and as Surety, are jointly and severally, firmly held and bound into the City of Broken Arrow the sum of One Hundred Sixty Thousand Four Hundred and No/100- dollars (\$ 160,400.00) lawful money of the United States of American, same being the approximate cost of the Contract herein referred to, for the payment of which sum well and truly to be made, we hereby bind ourselves, our heirs, executors, administrators, successors and assigns, jointly and severally, firmly by these presents.

***Great American Insurance Company**

THE CONDITION OF THIS BOND is such that the said Principal and Surety herein named do hereby agree and bind themselves unto and guarantee the City of Broken Arrow that all work done under said Contract was constructed with materials and in such a manner that the same shall endure without need of any repair whatsoever for a period of one (1) year from and after the formal acceptance of said project by the City of Broken Arrow, and that all the expense of said Principal and/or Surety, all failures occurring and arising from any defect in material or workmanship within said period of One (1) year shall be promptly repaired, within ten (10) days after notice to said Principal by letter deposited in the United States mail, addressed to said Principal at 1216 E. Kenosha #327, Broken Arrow Okla. 74012 and copied to said Surety; and it being further agreed that upon the neglect, failure or refusal of the Principal to make any needed repairs or backfills upon said project or any work connected therewith within the aforesaid ten (10) day period or other City negotiated period that the said Principal and Surety shall jointly and severally be liable to the City of Broken Arrow, Oklahoma, for the costs and expenses of making such repairs or backfills, or making good such defects or imperfections.

NOW, THEREFORE, if the said Principal and Surety shall faithfully and securely keep and perform all the obligations herein provided to be kept and performed by them, or either of them, then this obligation shall be null and void and of no force and effect, otherwise to be and remain in full force and effect at all times.

Signed, sealed and delivered the 12th day of December, 20 23.

Momentum Services, LLC

Contractor Principal

By: 

Brian A. Humberger owner/managing member
Title (seal)

Sharon Stone
Attorney in Fact - Sharon Stone

Attest:

Title

Surety (seal)

Great American Insurance Company

(Accompany this bond with Power of Attorney)

GREAT AMERICAN INSURANCE COMPANY®

Administrative Office: 301 E 4TH STREET • CINCINNATI, OHIO 45202 • 513-369-5000 • FAX 513-723-2740

The number of persons authorized by this power of attorney is not more than Eight

No. 0 22197

POWER OF ATTORNEY

KNOW ALL MEN BY THESE PRESENTS: That the GREAT AMERICAN INSURANCE COMPANY, a corporation organized and existing under and by virtue of the laws of the State of Ohio, does hereby nominate, constitute and appoint the person or persons named below, each individually if more than one is named, its true and lawful attorney-in-fact, for it and in its name, place and stead to execute on behalf of the said Company, as surety, any and all bonds, undertakings and contracts of suretyship, or other written obligations in the nature thereof; provided that the liability of the said Company on any such bond, undertaking or contract of suretyship executed under this authority shall not exceed the limit stated below.

Name	Address	Limit of Power
Timothy W. Driskill	Dawn Reside	All
Guy Griggs	Sharon Stone Tulsa, Oklahoma	\$100,000,000
Sylvia M. Hyde	Lynn Pelnik	
Jeff R. Johnson	Joe Sanchez	

This Power of Attorney revokes all previous powers issued on behalf of the attorney(s)-in-fact named above.

IN WITNESS WHEREOF the GREAT AMERICAN INSURANCE COMPANY has caused these presents to be signed and attested by its appropriate officers and its corporate seal hereunto affixed this 31st day of May, 2023.

Attest

GREAT AMERICAN INSURANCE COMPANY



Atty C. B.

Assistant Secretary

Mark V. Vicario

Divisional Senior Vice President

STATE OF OHIO, COUNTY OF HAMILTON - ss:

MARK VICARIO (877-377-2405)

On this 31st day of May, 2023, before me personally appeared MARK VICARIO, to me known, being duly sworn, deposes and says that he resides in Cincinnati, Ohio, that he is a Divisional Senior Vice President of the Bond Division of Great American Insurance Company, the Company described in and which executed the above instrument; that he knows the seal of the said Company; that the seal affixed to the said instrument is such corporate seal; that it was so affixed by authority of his office under the By-Laws of said Company, and that he signed his name thereto by like authority.



SUSAN A KOHORST
Notary Public
State of Ohio
My Comm. Expires
May 18, 2025

Susan A Kohorst

This Power of Attorney is granted by authority of the following resolutions adopted by the Board of Directors of Great American Insurance Company by unanimous written consent dated June 9, 2008.

RESOLVED: That the Divisional President, the several Divisional Senior Vice Presidents, Divisional Vice Presidents and Divisional Assistant Vice Presidents, or any one of them, be and hereby is authorized, from time to time, to appoint one or more Attorneys-in-Fact to execute on behalf of the Company, as surety, any and all bonds, undertakings and contracts of suretyship, or other written obligations in the nature thereof; to prescribe their respective duties and the respective limits of their authority; and to revoke any such appointment at any time.

RESOLVED FURTHER: That the Company seal and the signature of any of the aforesaid officers and any Secretary or Assistant Secretary of the Company may be affixed by facsimile to any power of attorney or certificate of either given for the execution of any bond, undertaking, contract of suretyship, or other written obligation in the nature thereof, such signature and seal when so used being hereby adopted by the Company as the original signature of such officer and the original seal of the Company, to be valid and binding upon the Company with the same force and effect as though manually affixed.

CERTIFICATION

I, STEPHEN C. BERAHA, Assistant Secretary of Great American Insurance Company, do hereby certify that the foregoing Power of Attorney and the Resolutions of the Board of Directors of June 9, 2008 have not been revoked and are now in full force and effect.

Signed and sealed this 12th day of December, 2023.



Atty C. B.

Assistant Secretary

**SECTION IV.
CITY OF BROKEN ARROW'S
STANDARD CONTRACT TERMS
AND CONDITIONS FOR A PUBLIC
CONSTRUCTION PROJECT**

4.6. The City shall not be liable or responsible to the Contractor, Surety or any other person for or on account of any Work stoppages or delays arising out of an injunction or any other kind of legal or equitable proceeding or from, by or on account of any other cause whatsoever.

4.7. If the Contract be amended in any material respect and the City determines that such amendment will cause delay in the completion of the Work, the City shall postpone the completion time by the number of days it determines to be equitable.

4.8. If the Contract Administrator suspends the Work in whole or in part the Contract Administrator shall postpone the time for completion of the Work by the number of days, if any, that the Contract Administrator determines to be equitable.

4.8.1. The Contract Administrator may instruct the Contractor to delay the start of the Work or suspend the operations in whole or in part for the length of time the Contract Administrator may deem necessary because of conditions that the Contract Administrator considers unfavorable for commencement of the Work. In such an event, the Contractor shall start or resume the Work when notified to proceed by the City Contract Administrator.

4.9. If the Contractor fails to perform or complete any of the Work to the reasonable satisfaction of the City within any of the times allowed by the Contract or if the Contractor fails to discharge any of the Contract obligations, the City may, upon written notice to the Contractor, terminate the Contract. Failure of the City to exercise its rights to terminate shall not be deemed a waiver of said right or any other rights or privileges hereunder or by law with respect to any continuing or subsequent breaches of this Contract.

4.9.1. If the City terminates the Contract as provided herein, no payments of any type, other than payment due and payable at the time of termination shall thereafter be made to the Contractor. The default in completing the Work within the time allowed by the Contract will result in the payment of liquidated damages. The City shall recover liquidated damages by deducting the amount thereof out of any monies due or that may become due the Contractor and if said monies are insufficient to cover said damages, then the Contractor or the Surety shall pay the amount due.

5.0 LIQUIDATED DAMAGES

5.1. Liquidated damages for this Contract are the sum of **One Thousand dollars and no cents** (\$ **1,000.00**) per day for each day the Contractor exceeds the Contract time for completion. This amount is fixed and agreed upon because of the impracticability and extreme difficulty of fixing and ascertaining the actual damages sustained by the City in such event.

6.0 CONTRACTOR'S DUTIES AND RESPONSIBILITIES REGARDING THE WORK

6.1. The Plans and Specifications that indicate general outlines and details necessary for a comprehensive understanding of the Work are part of the Contract and are on file in the Contract Administrator's office. The Contractor will receive five copies of these Plans and Specifications, free of charge. The Contractor shall keep one copy of each at the site of the Work. The Work shall be constructed in all respects in compliance with requirements of the Plans and Specifications. The approved Plans and Specifications will be supplemented by working and Supplemental Drawings as necessary to adequately define the requirements and information given on the approved Plans and Specifications. No changes shall be made on any Plan and Specification or Drawing after the same has been prepared or approved by the Engineer, except on the direction of the Engineer.

6.1.1. The Contractor shall furnish, on sheets of the size required by the Engineer, such working Drawings not furnished by the City as may be required by the Engineer for any part of the finished construction. Upon completion of the Work, the Contractor shall deliver to the City a complete set of said Drawings on a good-quality bond paper. Shop Drawings may be submitted in pencil on a good grade of tracing paper.

6.1.1.a. The compensation of the Contractor for furnishing all working Drawings shall be included in the prices Bid for the various scheduled items.

CITY OF BROKEN ARROW'S STANDARD CONTRACT TERMS AND CONDITIONS FOR
A PUBLIC CONSTRUCTION PROJECT

1.0 DEFINITIONS

1.1 The following Definitions are for terms utilized in the Contract Documents. Whenever these terms appear in any of the Contract Documents relating to this Public Construction Project, the following terms (or pronouns in place of them) and definitions for those terms govern. If a term is defined but is not utilized within any of the Contract Documents for a particular Public Construction Project, then it will not apply.

1.1.1. AASHTO means the American Association of State Highway and Transportation Officials.

1.1.2. Addenda means any additional or supplemental documents, which were not included with the Bid packet and are usually written interpretations or modifications of the Contract Documents, provided prior to Bid opening.

1.1.3. ASTM means the American Society of Testing and Materials.

1.1.4. AWWA means the American Water Works Association.

1.1.5. Bid means the Bidder's Proposal with all documents attached thereto by the Bidder, submitted by the Bidder to perform the Work, which Bid shall become a part of the Contract Documents upon becoming successfully awarded to the Bidder.

1.1.6. Bidder means any person, partnership, joint venture or corporation submitting a Proposal for performing the Work.

1.1.7. Bond(s) mean(s) the Proposal Guaranty, Performance Bond, Statutory Bond or Maintenance Bond furnished by the Contractor and the Surety to the City as a guaranty that the Contractor will enter into a Public Construction Contract with the City and completely perform the Contract according to its terms and conditions.

1.1.8. City means the City of Broken Arrow, Oklahoma, a municipal corporation or any of its Trusts or Authorities as indicated by the entity executing this Contract, its duly elected and qualified governing body and/or its agents and officers duly authorized to act for the City or to represent the City relative to this Contract and to perform the powers and duties specified by the City hereunder.

1.1.9. Change Order(s) mean(s) a written order to the Contractor for Extra Work, increases or decreases in Contract quantities and additions or alterations to the Plans or Specifications, within the scope of the Contract.

1.1.10. Construction Project means the Public Construction Project for which the Work is to be completed under the Contract Documents.

1.1.11. Contract means the Public Construction Contract, executed by the parties, which pertains to the performance of and the furnishing of labor and materials for the Work on the Public Construction Project. The Contract includes all of the Contract Documents, whether attached thereto or incorporated by reference.

1.1.12. Contract Administrator means the City representative primarily responsible for administration and oversight of the Contract. The Contract Administrator will be the Director of Engineering and Construction or the Director of Engineering and Construction's designee or the

Contract Administrator may be the Project Engineer however the Contract Administrator does not have to be the Project Engineer. (See Definition for Project Engineer)

1.1.13. Contract Documents mean all the documents included in the Bid Packet, which includes, but is not limited to, the Notice to Bidders, Invitation to Bid, Instructions to Bidders, Proposal Form, Performance Bonds, Statutory Bonds, Maintenance Bonds, the successful Bidder's Bid, City of Broken Arrow's Standard Contract Terms and Conditions for Public Construction Projects and the Plans and Specification, other Drawings, Supplemental Agreements, Supplemental Plans and Specifications, other Drawings and/or other data and may also refer to the unsigned forms of such documents.

1.1.14. Contractor means the corporation, partnership, company, firm or individual, named and designated in the Contract and who has entered into this Contract or the performance of the Work covered thereby and/or the Contractor's duly authorized agents and other legal representatives.

1.1.15. Days mean calendar days unless otherwise specified.

1.1.16. Drawings means and includes all Drawings, Plans or other Drawings prepared by the City or by an Architect/Engineering firm contracted with the City that were included in the City's Proposal for Bids; all Drawings submitted by the successful Bidder with the successful Bidder's Proposal and used as a basis for the successful Bid; all Drawings by the Contractor when and as approved by the Contract Administrator and/or Engineer; and all Drawings submitted by the City to the Contractor during the progress of the Work as provided for herein.

1.1.17. Engineer means the Director of Engineering and Construction of the City or the engineer or engineers who have been designated, appointed or employed by the City for this Work or the Engineers' duly authorized agents; such agents acting within the scope of the particular duties entrusted to such agents in each case.

1.1.18. Extra Work means, Work that is unforeseen or Work made necessary by alteration of Plans and Specifications or necessary to complete the Work for other reasons, for which no specific prices or compensations are provided in the Contract. Extra Work shall be performed by the Contractor in accordance with the Plans and Specifications and as directed; provided, however, before any Extra Work is started, a written order from the Contract Administrator shall be delivered to the Contractor to do the Extra Work.

1.1.19. Inspector means the authorized representative of the Engineer or the technical inspector or inspectors duly authorized by the Contract Administrator, assigned to make a detailed inspection of any or all portions of the Work, or materials thereof.

1.1.20. Laboratory means the laboratory or laboratories employed by the Contractor for testing the materials used in the Work.

1.1.21. Lump Sum means the price or an item of Work including all things necessary to complete the item as shown on the Plans and Specifications. Such an item is not measured in units but is defined by description.

1.1.22. Maintenance Bond means the Surety Bond that secures that the Work performed was in accordance with the Contract Documents and that for a period of time after completion of the Work the Contractor will continue to perform such maintenance and/or repairs on the Project arising from any failures or defects in materials or workmanship or asset set out in the Contract Documents.

1.1.23. Materials mean all raw and prepared materials and manufactured and fabricated products entering into the finished Work.

1.1.24. Notice to Bidders means the notice provided by the City to Bidders to inform them of the

Public Construction Project and Work contemplated by this Contract.

1.1.25. Performance Bond means the Surety Bond that secures that the Work to be done in accordance with the Contract Documents and will be performed in the entirety.

1.1.26. Plans and Specifications means those specific items or Drawings identified for this Public Construction Project regarding construction equipment, construction details, material details, details pertaining to the methods of manner of performing the Work, the equipment to be used, or to the quantities or qualities of materials to be furnished for the Work, which are bound into and are a part of the Contract Documents. They also include the official Drawings or Plans and the profiles, typical cross sections, general cross sections, working Drawings and supplemental Drawings, or exact reproductions thereof, prepared or approved by the Engineer, which show the location, character, dimensions and details of the Work.

1.1.27. Project means the Public Construction Project and the Work contemplated by this Contract.

1.1.28. Project Engineer means the Professional Engineer responsible for interpreting Plans and Specifications and/or Drawings for the Project. The Project Engineer may also act as the Contract Administrator.

1.1.29. Proposal means the offer of the Bidder to perform the Work, when completed and submitted on the prescribed Proposal Form, properly signed.

1.1.30. Proposal Form means the form required by the City, prepared and submitted by the Bidder to make a formal Bid for the performance of the Work.

1.1.31. Proposal Guarantee means the security furnished by the Bidder as a guaranty that the Bidder will enter into the Contract with the City to complete the Work if the Bidder is the successful Bidder and that the Bidder will secure the performance of the Contract.

1.1.32. Public Construction Project means any one of the numerous Projects commenced by the City and paid for out of public funds. It may include any number of parts or divisions, which the Work is divided for the purpose of awarding Public Construction Contracts. Any one (1) Public Construction Contract may, when provided for in the applicable Notice to Bidders, cover Work for more than one Public Construction Project.

1.1.33. Public Road means any road, highway, street, alley or way, which is open or has been dedicated to be used by the public, regardless of by whom, or by what agency or divisions of government, it is owned, controlled or maintained.

1.1.34. Special Provisions means the portion of the Contract setting forth terms and conditions or requirements peculiar to the Work or materials involved in the Proposal and not satisfactorily or completely covered by the Standard Contract Terms and Conditions or the Supplementary Plans and Specifications or may be utilized for setting out additional terms and conditions and/or covenants of the Contract.

1.1.35. Statutory Bond means the Surety Bond that secures the Work will be done in accordance with the Contract Documents, which includes the furnishing of all necessary tools, equipment, material and labor, in accordance with the Contract Documents.

1.1.36. Subcontractor means any person, partnership, joint venture or corporation undertaking to perform any part of the obligations of the Contractor, with the written consent of the Contract Administrator.

1.1.37. Superintendent means the executive representative of the Contractor, present on the Work at all times during its progress, authorized to receive and fulfill instructions from the Engineer,

and capable of superintending the Work efficiently.

1.1.38. Supplemental Agreements means written agreements executed by the Contractor and by the City covering alterations necessary to the Work, as hereinafter provided.

1.1.39. Supplemental Plans and Specifications means additions to and amendments of the General Specifications. Included in them will be construction and materials Specifications, and provisions regarding pay items, relating to the Work. Only those portions of the Supplemental Specifications, which are specifically mentioned in the Notice to Bidders or the Proposal, constitute a part of the Contract Documents.

1.1.40. Surety means the corporate body which, or the individual or individuals who, is bound with and for the Contractor under the Performance Bond for the performance of the Contract according to its terms, under the Statutory Bond as required by law, the Maintenance Bond for the performance of maintenance according to its terms. A Surety company authorized to do business in the State of Oklahoma, having a local representative, and satisfactory to the City, will be required as Surety on the required bonds.

1.1.41. Surety Bonds means the Performance Bond, Statutory Bond, the Maintenance Bond and the Bond required by the Oklahoma Tax Commission for non-resident contractors and non-resident subcontractors.

1.1.42. MUTCD means the Manual on Uniform Traffic Control Devices for Streets and Highways, most current edition.

1.1.43. Unit Price means the price per specified unit of measurement of Work and/or material.

1.1.44. Work means all work specified in the Specifications or indicated on the Plans for the contemplated construction and covered by the Contract.

1.2. Whenever the words "as ordered", "as permitted", "as directed", or words or phrases of like significance are used, it is understood by the parties that the order of directions, requirements, permissions or allowances of the Contract Administrator govern.

1.3. Similarly, the words, "approved," "reasonable," "suitable," "acceptable," "proper," "satisfactory" or words of like effect and significance, unless otherwise specified herein, shall mean approved, reasonable, suitable, acceptable, proper or satisfactory as in the judgment of the Contract Administrator.

2.0 SCOPE

2.1. The Contract Terms and Conditions, which follow, are general in scope and may refer to conditions that will not be encountered in the performance of the Work included in this Public Construction Contract and are therefore not applicable hereto. Any Terms and Conditions, requirements, provisions or other stipulations of the Contract Documents, which pertain to a nonexistent condition and are not applicable to the Work performed hereunder, shall have no meaning to the Contract. All Terms and Conditions, requirements, provisions or other stipulations that are encountered in the performance of the Work or are significant to the Terms and Conditions of the Contract shall fully apply and be strictly adhered to.

2.2. The Plans and Specifications are intended to supplement, but not necessarily duplicate each other and together constitute one (1) complete set of Plans and Specifications, so that any Work exhibited in the one and not in the other shall be executed just as if it had been set forth in both, so that the Work shall be completed according to the complete design or designs as decided and determined by the Engineer.

2.3. Should anything be omitted from the Plans and Specifications that was not previously identified prior to the Contract being awarded to the Contractor and which is necessary for a clear understanding of the Work or it appears that various instructions are conflicting, then the Contractor shall request written instructions from the Engineer to clarify such omissions or discrepancies.

2.4. The Plans and Specifications and all Supplemental Documents are an essential part of the Contract and a requirement appearing in one is as binding as if it appeared in all. All Contract Documents are intended to be complementary to complete the Work.

2.4.1. In case of a discrepancy in the dimensions, the governing ranking will be: 1) Plans and Specifications Dimensions; 2) Calculated Dimensions; 3) Standard Specifications; 4) Standard Plan Sheets; 5) Scaled Dimensions.

2.4.2. In case of a discrepancy in the information, the governing ranking will be: 1) Plans and Specifications; 2) Supplemental Specifications; and 3) Standard Plan Sheets.

2.4.3. The Addenda attached to the Contract shall govern over all Contract Documents except Amendments or modifications to the Contract authorized by the City and executed by the parties.

3.0 CONTRACT ADMINISTRATOR'S POWER AND DUTIES

3.1. The Contract Administrator shall give all orders and directions contemplated under the Contract Documents relative to the execution of the Work. The Contract Administrator shall determine the amount, quality, acceptability and fitness of the several kinds of work and materials, which are to be paid for under this Contract and shall decide all questions relative to said Work and the construction thereof. The Contract Administrator's estimates and decisions shall be final and conclusive, except as herein otherwise expressly provided. In case any questions shall arise between the parties hereto relative to the Contract Documents, the Contract Administrator's determination or decision shall be a condition precedent to the right of the Contractor to receive any money under this Contract for anything affected in any manner or extent by such questions.

3.2. The Contract Administrator or Project Engineer shall decide the meaning and intent of any portion of the Plans and Specifications or Drawings, where the same may be found obscure or be in dispute; and the Contract Administrator or Project Engineer shall have the right to correct any errors or omissions therein when such corrections are necessary to properly perform the intent of Plans and Specifications or Drawings. Any such corrections shall be implemented immediately from the time that the Contract Administrator gives notice, in writing thereof, to the Contractor.

3.3. Any differences or conflicts, which may arise between the Contractor and other contractors with the City in regard to the Work to be performed under this Contract shall be determined and resolved by the Contract Administrator.

3.4. Nothing in this Section 3 shall be construed as authorizing any changes to the Contract that increase the Contract cost to the City, decrease the aggregate value of the materials furnished to the City or increase the time of completion. Such changes to the Contract can only be made in writing and shall be executed by the parties in the manner set out herein.

3.5. Nothing in this Section shall be construed to forbid conferences between the Contractor and the City in the case of actual disputes with the Contract Administrator; provided that the Contract Administrator and the Contractor must negotiate in good faith in an attempt to resolve any disputes prior to and as a condition for such issues being raised and discussed with the City. The City reserves the right to require the Contract Administrator and the Contractor to agree upon any proposed changes or to get a full and complete report from both the Contractor and the Contract Administrator and reserves the right to conduct an independent investigation prior to responding to any dispute that cannot be resolved between the Contract Administrator and the Contractor.

3.6. The Contract Administrator or Project Engineer shall decide all questions, which may arise as to the quality or acceptability of materials furnished and Work performed, as to the manner of performance and rate of progress of the Work, whether or not such questions involve the interpretation of the Plans and Specifications. The Contract Administrator's or Project Engineer's decision on such questions shall be final and the Contract Administrator or Project Engineer shall have executive authority to enforce and make effective such decisions and orders.

4.0 TIME FOR COMPLETION

4.1. The Work shall be commenced within ten (10) days from and after the date of written order from the City. The Contractor agrees that the Work shall be prosecuted regularly, diligently and uninterruptedly at a uniform rate of progress to ensure completion within the number of days stated in the Proposal. It is understood and agreed that the said time for the completion of the Work described herein is a reasonable time for the completion of the same.

4.2. If required by the Contract, the Contractor shall furnish the Contract Administrator with a proposed progress schedule, in a format approved by the Contract Administrator, setting forth in detail the procedure the Contractor proposes to follow, giving the dates that the Contractor expects to start and complete separate portions of the Work. If the Contract Administrator deems it desirable, the Contract Administrator may require the Contractor to furnish revised progress schedules not less often than quarterly. Such revised progress schedules shall show the start dates and the completion dates (or proposed completion dates) of all or any portion of the Work that such a revised schedule is required.

4.3. Time is of the essence for completion of this Contract. If the Contractor fails to complete the Work within the time specified, then the Contractor agrees to pay the City, not as penalty, but as liquidated damages for such breach of Contract, the amount set forth in the Contract Documents for each day of failure to complete the Work after the specified time set forth in the Bid Proposal. In the event the Contractor does not maintain the Work schedule approved by the Contract Administrator, a sum equal to the liquidated damages for the number of days Contractor is behind schedule may be retained by the City out of the amounts due the Contractor from time to time, to guarantee the City against losses by reason of the failure of the Contractor to complete the Work or any part thereof in the time provided herein. The amount of damages finally determined to be due may be withheld from any sums finally determined to be due Contractor hereunder, or otherwise.

4.4. If the Plans and Specifications set a definite and certain time for the performance of any act and the Contract allows additional time for the completion of any Work, the additional time for completion shall govern in this Contract.

4.5. Should the Contractor be delayed in the final completion of the Work by any act or neglect of the City or Contract Administrator or by any employees of either or by strikes, injunctions, fire or other force majeure and in the opinion of the Contract Administrator such delay could not have been anticipated or avoided, then an extension of time sufficient to compensate for such delay shall be granted by the City, provided, however, that the Contractor shall give the City and the Contract Administrator notice in writing of the cause of delay within ten (10) days of the occurrence of the event that caused the delay.

4.5.1. Force Majeure means an "Act of God" such as an earthquake, flood, cloudburst, cyclone or other cataclysmic phenomenon of nature beyond the power of the Contractor to foresee or to make preparation in defense against. A rain, windstorm or other natural phenomenon of normal intensity, based on U.S. Weather Bureau reports, for the particular locality and for the particular season of the year in which the Work is being done, shall not be construed as an Act of God and no extension of time will be granted for the delays resulting there from. No extension of time will be granted for any delay or suspension of the Work due to the fault of the Contractor. No extension of time on account of a delay due to unforeseen causes will be granted if a written request is not filed with the Contract Administrator within ten (10) days of the date of the occurrence of the Act of God.

6.19. Upon the presentation an authorized permit, which provides that all necessary repair work will be paid for by the party to whom such permit is issued, the Contract Administrator may authorize the Contractor to allow the party bearing such permit to make openings in the Work or in public roads crossing the Work.

6.20. The Contractor shall provide and maintain in a neat, sanitary condition such accommodations for the use of the Contractor's employees and City representatives to comply with the requirements and regulations of the Oklahoma Department of Health, Oklahoma Department of Environmental Quality, and other authorities having jurisdiction and shall commit no public nuisance. Portable facilities shall be provided at the Work sites.

6.21. No public road shall be closed to the public until the Contract Administrator has authorized such action in writing.

6.21.1. The Contractor shall notify the Contract Administrator in writing at least ten (10) days in advance of the date proposed to close any portion of a public road.

6.21.2. Unless otherwise indicated on the Plans and Specifications or in other Contract Documents, the width of the traveled roadway on the approaches to any bridge supporting a Public Road shall be not less than the width of the roadway of the bridge itself.

6.21.3. Materials stored upon the Right-of-Way or elsewhere shall be placed in a manner that causes no obstruction to the traveling public.

6.21.4. The Contractor shall furnish, erect, maintain and upon reopening the public road shall remove all barricades, Temporary Route, Road Closed, Load Limit, Warning and other required sign used for temporary routes or road closures. These signs, when utilized, including the signs utilized to close Public Roads at each point where traffic leaves it, shall be lighted and maintained by the Contractor.

6.21.5. When any Public Road is closed, the Contractor shall provide, erect and maintain barricades, approved by the Contract Administrator. The Contractor shall also provide, erect and maintain suitable and sufficient lights and danger signals (1) at the limits of each closed portion, (2) where other Public Roads intersect the Work and (3) at such other points as are shown on the Plans and Specifications, in accordance with the MUTCD.

6.21.6. When any Public Road is under construction, serving as a detour or is being used by the traveling public, the Contractor shall maintain, by the use of labor, equipment and materials, that portion of the Public Road being so used that it shall be kept smooth and free from holes, ruts, ridges, bumps, and dust, and it shall be sloped and provided with the necessary outlets to drain freely, including during periods of suspension of the Work. The Contractor shall maintain all structures on such portions of such Public Roads in a condition for safe and convenient use. The Contractor shall also furnish and maintain such guardrails, temporary guide markers as described in the MUTCD, lights, signs, other traffic-control devices, and flaggers as may be necessary to maintain safe traffic conditions. The Contractor may furnish, erect and maintain such additional signs and safety devices as they deem essential and as approved by the Contract Administrator.

6.21.7. The installation and operation of all traffic-control and safety devices shall conform to the requirements of the latest and current edition or revision of the MUTCD.

6.21.8. All flaggers furnished for the protection of the public and direction of traffic shall wear high-visibility safety apparel conforming to the MUTCD at all times during the performance of their duties. Flaggers shall be properly trained and shall perform their duties in a courteous manner to ensure the safety and convenience of the traveling public within the limits of the traffic

controlled area. The Contractor shall immediately correct any deficiency in number, equipment or procedure of flaggers which is brought to their attention by the Contract Administrator or otherwise.

6.21.9. Each flagger shall be supplied with the necessary equipment.

6.21.10. Between the hours of sunset and sunrise, each flagger shall be equipped with retro-reflectorized or lighted equipment conforming to the MUTCD. Except in emergency situations, flagger stations shall be illuminated at night.

6.21.11. At locations where workers and equipment are adjacent to the part of the highway used by the traveling public, construction and maintenance signage shall be installed in accordance to the MUTCD.

6.21.12. Whenever it is necessary to divert the flow of traffic from its normal lanes of travel into another lane of travel, the lane of travel for such diverted traffic shall be clearly delineated by temporary guide markers or barricades. On tangents, the temporary guide markers shall be spaced no farther apart than two hundred (200) feet; and on curves, as directed by the Contract Administrator. Between the hours of sunset and sunrise each temporary guide marker, unless suitably reflectorized, shall be illuminated by a warning lights placed on top of it, and each barricade shall be illuminated by sufficient warning lights and marked by reflectorized devices to make the temporary guide marker clearly visible. All markers, warning lights and reflectorized devices shall be furnished and maintained by the Contractor.

6.21.13. The Contractor may, in lieu of flaggers supplementing them, install and operate a manually controlled signal approved by the Contract Administrator. Where the vertical distance between the top edge of the pavement and the adjoining berm is four inches (4") or more, the Contractor shall, at the direction of the Contract Administrator, either correct the condition by placing suitable material against the edge of the pavement or may erect and maintain temporary guide markers as hereinbefore described.

6.21.14. Whenever one-way traffic is put into effect for a distance of not to exceed two hundred (200) feet, at least one (1) flagger shall be used during daylight hours and at least two (2) flaggers shall be used between sunset and sunrise. Whenever the length of one-way traffic exceeds two hundred (200) feet, a minimum of two (2) flaggers or traffic signals shall be used during the daylight hours. Whenever either end of a portion of a Public Road restricted to one-way traffic is not visible for an approach distance of at least five hundred (500) feet a sign or traffic signal approved by the Contract Administrator shall be placed approximately five hundred (500) feet from the end of the restricted area. The sign or traffic signal shall be properly lighted between the hours of sunset and sunrise. The Contractor shall furnish and maintain positive and quick means of communication between the flaggers or traffic signals at opposite ends of the restricted area. The Contractor shall keep the flaggers supplied with sufficient signaling equipment.

6.21.15. Equipment and materials stored on any Public Road shall at all times be marked. From the hour of sunset to sunrise, any such material or equipment stored between the side ditches or between the lines five (5) feet behind any raised curbs shall be clearly outlined with warning lights or other equally dependable devices in conformance with the MUTCD and approved by the Contract Administrator. In addition, when the restricted portion of a Public Road includes sidewalks, the Contractor shall provide any other light, barricades, etc., that may be needed for the protection of pedestrian traffic. No earth or other material shall be dumped or stockpiled on any new or existing pavement. Such material shall be kept clear of pavement areas at all times.

6.21.16. All barricades, signs, and obstructions shall be illuminated at night and all lights for this purpose shall be kept burning from sunset to sunrise. Between the hours of sunset and sunrise the Contractor shall provide and maintain two (2) red lights (one above the other) at each barricade and such other points as are necessary to protect the traveling public. When or where there occurs any direct or indirect damage or injury to public or private property, by or on account of an act,

omission, neglect or misconduct or in consequence of executing the Work, such property shall be restored by the Contractor at the Contractor's expense to a condition equal to that existing before such damage or injury was done, by repairing, rebuilding or otherwise restoring the same or the Contractor shall make good in a manner acceptable to the Contract Administrator and to the owner or owners of such property.

6.21.17. Opening of a Portion of the Work to Traffic and Acceptance of Structures. When a portion of Work is complete, that portion may be accepted and put in service when the City believes that such service will benefit the public or the City.

6.22. The Contractor shall cooperate with the Contract Administrator in protecting and preserving all cornerstones and monuments that are within the Right-of-Way of the Work or of any Public Road. The Contractor shall not start grading or other operations until the Contractor has referenced all known cornerstones, monuments and land markers in the Work area. Monuments, cornerstones and land markers unexpectedly encountered shall be protected, referenced and preserved.

6.22.1. When cornerstones, monuments and land markers are encountered in the performance of the Work and monument covers are not listed in the Contract Documents, the Contractor will furnish them. The Contractor will supervise the precise location and installation of the monument covers and will furnish all the labor, tools and other materials incidental to such installations.

6.22.2. The cost to the City for repair, re-determination of location and replacement of any cornerstone, monument or land marker within the Right-of-Way which is damaged, destroyed or made inaccessible during the progress of the Work by the Contractor in violation of these provisions is a charge deductible from any monies payable to him on account of the Work.

6.23. When the use of explosives is necessary for the prosecution of the Work, the Contractor shall use the highest degree of care so as not to endanger the life or property.

6.23.1. The Contractor agrees and warrants that the Contractor will observe Federal, State and local laws and ordinances and regulations relative to the use and storing of such explosives as may be used or kept on the job and all such storage places shall be marked clearly "DANGEROUS-EXPLOSIVES".

6.23.2. The attention of the Contractor is directed to the provisions of all City ordinances relative to the use, storage and transportation of explosives. A blasting permit must be obtained from the City Engineer's office prior to any blasting.

6.24. The Contractor shall adequately and suitably box, fence or otherwise protect all trees, other woody plants and vegetation that are to remain in place; and shall repair injuries to bark, trunk, limbs and roots of remaining plants by properly dressing, cutting and painting. The Contractor shall provide for safekeeping of cattle, horses and other animals by fencing the Work site. Gates shall be locked when not in use. The Contractor shall be responsible for the loss of animals as a result of the Work.

6.25. Before doing any Work over, under or near railroad tracks, telephone, power, sewer or pipelines the Contractor shall make, at his own expense, arrangements for properly securing and protecting the utilities until the Work is completed.

6.26. All work on navigable waters shall be conducted so the free navigation of the waterways will not be interfered with and the existing navigable depths will not be impaired.

6.26.1. In cases where Work is to be done in the bed of a navigable stream the Contractor shall advise the local U.S. Corps of Engineers of the intention to do such Work and the Contractor shall conform to such practices and regulations as the Corps of Engineers may deem necessary to protect water-borne traffic.

6.27. Within 24 hours after the occurrence of any accident or other event, which results in or might result

6.1.2. Working Drawings for any structure shall consist of such detailed Supplemental Plans and Specifications as may be needed for the prosecution of the Work and which are not included in the Plans and Specifications furnished by the City. They shall include shop details, erection plans, masonry-layout diagrams and bending diagrams for reinforcing steel and must be approved by the Engineer before any Work involving these Supplemental Plans and Specifications shall be performed. Plans for cribs, cofferdams, falsework, centering and formwork may be required by the Engineer, and in such cases shall be likewise subject to approval, unless approval be waived by the Engineer.

6.1.3. It is expressly understood and agreed that approval by the Engineer of the Contractor's working Drawings does not relieve the Contractor of any responsibility for accuracy of dimensions and details. The Contractor shall be responsible for obtaining the approval by the Engineer of his working Drawings and for their conformity with the Plans and Specifications.

6.2. If any Work consists of repairs, extensions, or alterations of existing structures, the Contractor shall make measurements of prior construction as may be required to accurately join the old construction with the new Work. Any measurements, which may appear in the Plans and Specifications that indicate the extent and nature of such repairs, extensions and alterations, shall not relieve the Contractor of this responsibility.

6.3. Finished surfaces in all cases shall conform to lines, grades, cross sections and dimensions shown on the Plans and Specifications. Any deviations from the Plans and Specifications and approved working Drawings may be required by the exigencies of construction and will in all cases be determined by the Engineer and authorized in writing.

6.4. The Contractor shall give the Work the constant attention that is necessary to facilitate the progress thereof and shall cooperate in every way possible with the Contract Administrator, Engineer, other Contractors, public agencies, railroads, public utilities and all other agencies and persons involved in the Work. The Contractor shall at all times have a competent Superintendent, capable of reading and thoroughly understanding the Plans and Specifications, who shall act as the Contractor's agent for the Work and who shall receive instructions from the Contract Administrator or Engineer.

6.4.1. Such Superintendent shall have full authority to execute and shall execute the orders and directions of the Contract Administrator without delay and shall promptly supply such materials, tools, equipment, and labor as may be required. Such Superintendent shall be furnished irrespective of the amount of Work sublet.

6.5. The Engineer will furnish survey data and benchmarks for the Work. The Contractor shall stake lines, grades, structures and temporary benchmarks and shall lay out from the Work to be performed under this Contract. The Contractor shall be responsible for the finished Work conforming to the lines, grades and benchmarks given by the Engineer. The Contractor shall establish offset base lines, reference points, slope stakes, supplementary benchmarks and any other horizontal and vertical control not established by the Engineer. The cost to the Contractor of laying out the Work as above described shall be included in the amounts Bid for the various scheduled items. The Contractor shall notify the Engineer in writing not less than five (5) days in advance, when benchmarks and section lines are required. Each request for stakes and other engineering services described herein shall, except in emergency, cover sufficient Work for not less than one (1) full day of the workforce needed for the Work. The Contractor shall exercise care in the preservation of stakes and benchmarks set for the Work. If any such stakes or benchmarks be damaged, lost, displaced or removed by the Contractor, the Contractor shall have them reset at the Contractor's expense.

6.6. The Contractor shall furnish the Engineer, laboratory representative and Inspectors with every reasonable facility for ascertaining whether or not the Work performed and materials used are in accordance with the requirements of the Contract. If the Engineer requests, the Contractor shall at any time before final acceptance of the Work remove or uncover such portion of finished Work as may be specified. After examination by the Engineer, the Contractor shall restore said portions of the Work to the

standard required by the Plans and Specifications. Should any portion of the Work thus exposed and examined prove acceptable, the uncovering or removing and the replacing of the covering or making good of the portion removed, will be paid for as Extra Work but should any portion so exposed and examined prove unacceptable, the uncovering or removing and the replacing of the covering or making good of the portion removed, shall be at the Contractor's expense. No Work shall be done nor materials used without suitable supervision by the Contractor or without inspection. Failure of the City to reject any defective Work or materials shall not in any way prevent later rejection when such defects are discovered.

6.6.1. When any railroad corporation is directly affected by the Work, the Work shall be subject to the inspection of its representatives. Such inspection shall not make the railroad corporation a party to this Contract, and will in no way interfere with the rights of either party hereunder.

6.7. Holes resulting from the removal of test cores shall be refilled by the Contractor with materials similar to that of the cores and be compacted and finished to conform to the surrounding construction. The cost of such Work shall be included in the amount of the Bid for the various scheduled items.

6.8. The Contractor, at his own expense, shall remedy, remove and/or replace all rejected Work in a manner acceptable to the Contract Administrator. Any Work done beyond the lines and grades shown on the Plans and Specifications or as given by the Engineer, except as herein provided, or any Extra Work done without authority, will be considered as unauthorized and at the expense of the Contractor, and will not be measured or paid for. Should the Contractor fail to remedy, remove and/or replace the rejected Work, the Contract Administrator shall have authority to cause any rejected Work to be remedied, removed or replaced and any unauthorized work to be removed and the costs thereof shall be deducted from any monies due or to become due to the Contractor.

6.9. The Contractor shall be responsible for all damages caused by his equipment or operations. No loads shall be placed or permitted on a pavement or base before the expiration of the curing period.

6.10. With respect to all Work performed under this Contract, the Contractor shall:

6.10.1. Comply with the safety standards provisions or applicable laws, building and construction codes and the requirements of the Occupational Safety and Health Act of 1970 (Public Law 91-596), as amended and the requirements of Title 20 of the Code of Federal Regulations, Section 1518 as published in the "Federal Register", Volume 36, No. 75 - Saturday, April 17, 1971, as amended.

6.10.2. Exercise every precaution at all times for the prevention of accidents and the protection of persons (including employees) and property.

6.10.3. Maintain at the Contractor's office or at an obvious location at the job site, all items necessary for giving first aid to anyone injured on the job site. In no case shall the Work commence until the Contractor has made standing arrangements for removal of injured persons to a hospital or a doctor's care.

6.10.4. During the performance of the Contract, if any operation, practice or condition is deemed unsafe by the Contract Administrator, the Contractor, when advised by the Contract Administrator, shall take any necessary corrective actions as shall be appropriate in the circumstances or as shall be directed by the Contract Administrator.

6.10.5. Nothing in the foregoing paragraphs shall be construed as relieving the Contractor from full responsibility for the safe prosecution of the Work at all times.

6.11. The Contractor shall provide all necessary pumps, drains, ditches and other means for removing water from the site of the Work, and shall satisfactorily remove the water. Contractor shall provide additional pumps or drains at any place where the Contract Administrator deems them necessary.

6.12. If performing the Work in any way involves cutting, obstructing, or otherwise making impassable, with safety, the traveled surfaces of any existing Public Road, the Contractor shall construct or otherwise provide and maintain in safe and passable condition, such detours, by-passes and temporary approaches, without undue delay to the traffic that passes over such Public Road. In all such cases, while performing the Work that in any way impedes traffic or endanger persons or property moving over Public Roads, the Contractor shall provide flagmen and warning signs and all other traffic and safety controls, as may be necessary for adequate protection of the traveling public against all hazards created or involved in performing the Work. The maintenance of a temporary way in a safe and passable condition shall include prompt snow removal and de-icing. When the Work affecting any Public Road prevents normal ingress to and egress from any lands abutting such Public Road, the Contractor shall construct or otherwise provide and maintain in safe and passable condition, temporary means of ingress to and egress from such lands; these shall be so maintained until the original means of ingress and egress are restored by the Contractor or until any permanent alternative means of ingress and egress required by the Plans and Specifications shall have been constructed and open to travel.

6.12.1. Unless and to the extent otherwise specifically provided in the Proposal, the cost of maintenance of local traffic shall be included in the amounts Bid for various scheduled items.

6.13. The Contractor shall provide for the removal of all dirt and materials that are spilled on existing pavements over which the dirt or materials are hauled or washed or otherwise deposited from the trucks utilized in performing the Work and whenever in the opinion of the Contract Administrator or the City of the existing pavement, the accumulation is sufficient to cause the formation of mud, interfere with drainage or create a traffic hazard.

6.14. All fences, buildings, non-used structures and obstructions of any character to the construction of the Work, which are within the limits of the right-of-way, shall be removed or otherwise disposed of by the Contractor.

6.15. The Contractor, subject to the approval of the Contract Administrator, may use in the performance of the Work, such stone, gravel, sand and other materials as may be found in any excavation, which the Contractor is required to make, and will be paid for the excavation of such materials, at the Contract prices therefor. However, the Contractor shall replace such materials, at their own expense, with other suitable material all of that portion of the material so removed and used as was provided in the Plans and Specifications to be used in embankments, backfills, approaches or otherwise. No charge for materials so used will be made against the Contractor except the replacement herein provided for. The Contractor shall not excavate nor remove any material from within the right-of-way, which is not a required excavation as indicated by the slope and grade line, without written authorization from the Contract Administrator.

6.16. Immediately upon completion of any portion of the Work, the Contractor shall restore all fills, topsoil and utilities to their location and condition prior to construction.

6.17. The City reserves the right to do work by other contractors or by City forces and to permit public utility companies and others to do work during the progress and within the limits of or adjacent to the Work. The Contractor shall conduct his Work and cooperate with such other parties so as to cause as little interference as possible with such other work and as the Contract Administrator may direct. The Contractor shall make no claims against the City for additional payment due to delays or other conditions created by the operations of such other parties. If there is a difference of opinion as to the respective rights of the Contractor and others doing work within the limits of or adjacent to the Work, the Contract Administrator will decide as to such rights in order to secure the completion of the Work. The Contract Administrator's decision shall be final and binding on the Contractor.

6.18. Upon commencing the Work, the Contractor shall have suitable photographs, or digital imaging satisfactory to the Contract Administrator, taken on or about the first of each month showing the general condition of the Work. Copies of each view shall be supplied to the Contract Administrator, without charge, as soon as practicable after the first of each month. The City shall retain the negatives or discs. The cost of furnishing the photographs shall be included in the amounts Bid for the various scheduled items

in, injury to person(s) or property, arising out of or involves any omission or act of the Contractor or any Subcontractor or any employee or agent of either in any manner from the performance of the Contract, the Contractor shall send written report of such accident or other event to the Contract Administrator and the City's Attorney, setting forth a full and precise statement of facts pertaining thereto. The Contractor shall also immediately send to the City's Attorney a copy of any summons, subpoena, notice or other document served upon or received by the Contractor or any Subcontractor or any agent, employee or representative of either, in connection with any matter before any court, arising out of the Contractor's Work or the performance of the Contract.

6.28. The Contractor shall cooperate with the owners and operators of all underground and overhead utility lines in the removal or rearrangement operations in order that their services may proceed in a reasonable manner, that duplication of rearrangement work may be reduced to a minimum and that services rendered by such owners and operators will not be unnecessarily interrupted.

6.28.1. In the event of intended or accidental interruption to utility services as a result of the Work, the Contractor shall promptly notify the proper authority. The Contractor shall cooperate with the said utility in the restoration of service as promptly as possible. In no case shall interruption to water service be allowed outside of working hours. Fire hydrants shall be accessible to the Fire Department at all times and no materials shall be kept or stockpiled within fifteen (15) feet of any fire hydrant.

6.28.2. The Contractor shall notify in writing the utility company and the municipal authorities that may be affected by any Work involving public utility facilities before commencing Work. Copies of all such notices shall be promptly filed with the Contract Administrator. The Contractor shall give notices for the removal or relocation of utilities in ample time. The Contractor shall locate all storm sewers, culverts, buried telephone or electrical conduits, cable television sanitary sewers, water mains, and gas mains that might interfere with the construction of the project.

6.28.3. The revision and crossings of the various types of lines shall be made as follows:

6.28.3.a. Storm sewers and culverts may be removed at the time of crossing or may be adequately braced and held in position while the pipe is placed beneath them. If the storm sewer or culvert is removed, it shall be replaced with pipe of the same type and size as that removed and it shall be re-joined to the undisturbed line with a joint satisfactory to the Contract Administrator. Backfill over the main up to and around the storm sewer shall be thoroughly compacted in order that no settlement will occur.

6.28.3.b. All overhead and buried telephone and electrical conduits, cable television and gas mains to be revised or crossed by the construction of this Project shall be protected in accordance with the directions of the utility company owning the conduits and/or mains. The Contractor shall notify the companies and obtain their permission before making any crossings or revisions. Any overhead cables, buried cables, conduits or gas mains damaged by the Contractor shall be repaired at the Contractor's expense to the satisfaction of the Contract Administrator.

6.28.3.c. The Contractor shall not remove any water or sanitary sewer lines except as directed by the Contract Administrator or as required by the Plans and Specifications and shall adequately brace and protect the lines from any damage during construction. The Contractor will repair any existing water main or sewer main or lateral line damaged by the Contractor's operations. The repairs shall be inspected by the Inspector. The Contractor shall notify the City immediately after damaging any pipe. The repairs will be made at the Contractor's expense.

6.28.3.d. The location of utility service lines serving individual properties are not shown on the Plans and Specifications and it shall be the Contractor's responsibility to make any necessary changes in the line and/or grade of such services or to secure the necessary changes to be made by the particular utility company involved or the owner thereof or by

an agent or independent contractor approved by such utility company or owner. Contractor shall pay the cost of all such revisions whether performed by the Contractor, the utility company or owner, or any contractor. In the event of interruption of a utility service as a result of accidental breakage, Contractor shall promptly notify the Contract Administrator and the owner of the utility and shall repair or cause the same to be repaired, in the same manner as necessary changes above provided. The Contractor shall do all things necessary to see that the restoration of service is accomplished as promptly as reasonably possible. All sanitary sewer service lines damaged shall be replaced as directed by the Contract Administrator regardless of type or kind of damage.

6.28.4. In the event the Contractor in any way fails to comply with the requirements of protecting, repairing and restoring of any utility or utility service, the Contract Administrator may, upon written notice, proceed to protect, repair, rebuild or otherwise restore such utility or utility service as may be deemed necessary and the cost thereof will be deducted from any money due or which may become due the Contractor pursuant to the terms of his Contract.

6.29. Necessary sanitary conveniences for the use of employees on the Work, properly secluded from public observation, shall be provided and maintained by the Contractor. The construction and location of the facility and disposal of the contents shall comply with all laws of the City and State, relating to health and sanitation regulations.

6.30. Electronic Transmission of Submittals:

6.30.1. Transmittals must be made electronically.

6.30.1.a. Contractor shall utilize Primavera Submittal Exchange®. Initial fees and subscription costs for this application shall be included in the Contractor's bid.

6.30.1.b. Protocols and processes will be determined at the Pre-Construction Conference.

6.30.2. Provide documents in Adobe Acrobat Portable Document Format (PDF), latest version.

6.30.3. Do not password Protect or lock the PDF document.

7.0 CONTRACTOR'S OBLIGATION AND RISK

7.1. The performance of the Contract and the Work is at the risk of the Contractor until the final acceptance and payment by the City. The Contractor shall take all responsibility of the Work and shall bear all losses that may arise out of the character of the Work, the nature of the land in or upon which the Work is done, whether or not it is due to the fact that the land is different from what is assumed or expected or on account of inclement weather, floods, fire, windstorm or other actions of the elements or any other cause or causes. The Contractor, at Contractor's expense, shall restore the same or remedy the damage.

7.2. Unless otherwise provided by the Plans and Specifications, all materials, supplies, machinery and equipment are warranted new, first-class, of the best of their kind and grade and all of the Work performed by Contractor shall be good, first-class and workmanlike. Contractor warrants that all machinery and equipment furnished will operate properly and perform the Work for which it was purchased. All warranties for the materials, supplies, machinery, equipment and Work herein shall survive acceptance and payment for the Work.

7.3. Unless otherwise expressly omitted, the Contractor shall perform all Work and furnish all supplies and materials, machinery, equipment, facilities and means, necessary or proper to perform and complete all the Work required by this Contract within the time herein specified and in accordance with the provisions of the Contract Documents. The Contractor shall observe, comply with, and be subject to all Terms and Conditions, requirements and limitations of the Contract and shall complete all of the Work contemplated by this Contract to the satisfaction of the Contract Administrator and the City.

8.0 CONTRACTOR TO CHECK DRAWINGS AND SCHEDULES

8.1. The Contractor shall check all dimensions, elevations and quantities shown on the Plans and Specifications and estimates or schedules given to the Contractor by the Contract Administrator; and shall notify the Contract Administrator of any discrepancies. The Contract Administrator or Project Engineer will provide corrections, interpretations and instructions necessary to perform the intent of the Contract and the Contractor shall carry out such instructions as if originally specified.

8.2. Figured dimensions govern. Indicated dimensions, when given on the Plans and Specifications, shall be accurately followed, even though they differ from the scale measurements. If dimensions are not indicated on the Plans and Specifications, then the Contractor shall not perform the Work until such time that the Contractor has received written instructions from the Engineer regarding the dimensions to be used.

8.3. Any Work done without being properly located and established by base lines, off-set stakes, bench marks or other basic reference points, which are located, established or checked by the Engineer, may be required to be removed and replaced at the Contractor's cost or expense.

9.0 DRAWINGS FURNISHED BY CONTRACTOR

9.1. The Contractor shall furnish all shop, fabrication, assembly, foundation and other Drawings required by the Plans and Specifications; Drawings of equipment and devices, offered by the Contractor for approval of the Contract Administrator, in sufficient detail to adequately show the construction and operation thereof; and Drawings depicting essential details of any changes in design or construction proposed by the Contractor in lieu of the design or arrangement required by the Contract or any item of Extra Work. The Contractor shall submit to the Contract Administrator the number of copies required by Contract Administrator of each such Drawing for the Contract Administrator's approval. After approval by the Contract Administrator, all such Drawings shall become a part of the Contract Documents and the work or equipment shown therein shall be in conformity therewith unless otherwise required by the Contract Administrator.

9.2. The Engineer's check and approval of Drawings, submitted by the Contractor, will apply to the general conformity of the Plans and Specifications and does not constitute a comprehensive approval of all of the dimensions, quantities and details of the material or equipment depicted therein; nor does such check and approval relieve the Contractor of the Contractor's responsibility for errors contained in such Drawings.

10.0 PATENT RIGHTS

10.1. All fees for any patented invention, article or arrangement that is based upon, or in any manner connected with, the construction, erection or maintenance of the Work or any part hereof embraced in this Contract and these Specifications, shall be included in the Proposal amounts in the Contract for said Work. The Contractor shall protect and hold harmless the City against any and/or all demands of such fees or claims.

11.0 MODIFICATION AND ALTERATIONS

11.1. The Contractor agrees that the City has the right to make such modifications, changes and alterations as the City may see fit in any part of the line, grade, form, arrangement, dimension, extent or in the materials to be used in or of the Work contracted to be done without affecting the validity of the Contract or the liability of the Sureties upon the performance of this Contract or the Bonds.

11.2. Where any modification, change or alteration increases the quantity of Work to be performed and is within the scope of a fair interpretation thereof, such increase shall be paid for according to the quantity of Work actually done, either at unit prices included in the Contract, or in the absence of such unit, as Extra Work. Modifications and alterations, which reduce the quantity of Work to be done, shall not

constitute a claim for damages for loss of anticipated profits on the Work or materials involved in such reduction.

11.3. The Contract Administrator shall determine, on an equitable basis, the amount of credit due the City for Contract Work not performed as a result of modifications or alterations authorized hereunder where the value of the omitted Work is not fixed by unit prices in the Contract. The Contract Administrator shall give an allowance to the Contractor for any actual loss incurred in connection with the purchase, delivery and subsequent disposal of materials and equipment required for use on the Work as actually built; and shall make any other adjustment of the Contract amount where the method to be used in making such adjustment is not clearly defined in the Contract Documents. In this respect, such determination shall be final and binding only when approved in writing by the City and/or the Contract Administrator.

11.4. All orders for modifications, changes or alterations in the Work as herein provided shall be in writing, either by the Contract Administrator or by the City Manager through the direction of the City Council. Provided, however, all orders for modifications, changes or alterations in the Work, which increase the amount of money due the Contractor less than twenty-five thousand dollars (\$25,000.00) may be approved by the City Manager, increases in excess of twenty-five thousand dollars (\$25,000.00) must be approved in advance by the City Council and shall be in writing and executed by the parties in order to be binding.

12.0 SUSPENSION OF WORK ON NOTICE

12.1. The Contractor shall delay or suspend the progress of the Work or any part thereof, whenever the Contractor is required by written order of the City or Contract Administrator and for such periods of time as determined by the City. Any such order shall not modify or invalidate in any way the provisions of this Contract.

13.0 CITY'S RIGHT TO TERMINATE CONTRACT

13.1. In addition to any other right set out in the Contract Documents, the City has and retains the right to terminate the Contract, upon giving written notice to the Contractor for the following:

13.1.1. If the Contractor abandons the Work by moving equipment off-site and does not man the job for a period of five (5) working days.

13.1.2. If the Contractor assigns this Contract by a method otherwise than as herein provided.

13.1.3. If the Contractor is adjudged bankrupt.

13.1.4. If a general assignment of the Contractor's assets be made for the benefit of his creditors.

13.1.5. If a receiver should be appointed for the Contractor or any of his property.

13.1.6. If at any time the Engineer shall certify in writing to the City that the performance of the Work under this Contract is being unnecessarily delayed.

13.1.7. If at any time the Engineer shall certify in writing to the City that the Contractor is willfully violating any of the conditions or covenants of this Contract.

13.1.8. If at any time the Engineer shall certify in writing to the City that the Contractor is executing the Work in bad faith or otherwise not in accordance with the terms of this Contract.

13.1.9. If the Work be not substantially completed within the time named for its completion, or within the time to which such completion date may be extended.

13.2. The City will serve written notice upon the Contractor and their Surety of the City's intention to terminate this Contract. The notice will state that the Contract shall cease and terminate unless within five

(5) working days after the notice is served, a satisfactory arrangement is made for the continuance of the Contract.

13.3. In the event of termination, the Surety shall have the right to take over and complete the Work. The Surety must commence performance of the Contract or make a satisfactory arrangement for the continuance of the Contract within twenty (20) working days from the date of notice of termination.

13.4. If the Surety does not perform the Contract or make satisfactory arrangements for the completion of the Work within twenty (20) working days from the date of the notice of termination, the City may take over the Work and prosecute it to completion. The City may complete the Contract with a new Contractor or with its own work force. The Contractor and the Contractor's Surety shall be liable to the City for any and all excess costs sustained by the City by reason of such prosecution and completion of the Work.

13.5. In the event of termination of the Contract, the City may take possession of and utilize in completing the Work all such materials, equipment and tools as may be on site of the Work. If the City chooses not to use the materials and equipment left on site, it will notify the Contractor and the Contractor will have ten (10) working days to remove said items from the Work site. After the ten (10) working day period the remaining materials and equipment will be considered abandoned by the Contractor and will be disposed of by the City, and the Contractor will have no claim against the City for said disposal of abandoned items.

14.0 CONTRACTORS' RIGHT OF PROTEST

14.1. If the Contractor considers any work demanded to be outside the requirements of the Contract or considers any record or ruling of the Contract Administrator to be unfair, the Contractor shall immediately request the Contract Administrator provide written instructions or decisions, whereupon the Contractor shall proceed, without delay, to perform the Work in conformance with the instructions or decisions. Within ten (10) days after the date of receipt of the written instructions or decisions, the Contractor shall file a written protest with the Contract Administrator, stating clearly and in detail the basis of the objections. Except for such protest and objections made of record in the manner herein specified and within the time stated, the instructions or decisions of the Contract Administrator shall be final and conclusive. Contractor may protest and claim against the instructions and decisions of the Contract Administrator between the Plans and Specifications, and the conditions on the ground, or any errors or omissions in the Plans and Specifications, estimates, or layout as given by stakes, points or instructions, which may be discovered in the course of the Work. The Contractor may not take advantage of any errors or omissions in the Plans and Specifications, as full instructions contained in letters transmitting Plans and Specifications to the Contractor shall be considered as written instructions or decisions. In the event the Contractor suffers actual damages as a result of the written instruction or decisions under protest for which the Contractor seeks to hold the City liable, Contractor must submit a written itemized statement of costs within thirty (30) days of the discovery of the claimed loss and allow the City access to all Contractors' records to audit the claim. Failure of Contractor to timely file the statement or to allow the audit waives any recovery for damages.

15.0 EXTRA WORK

15.1. If the Contractor does any work or furnish any materials, which are not classified under any of the terms of this Contract and are necessary in order to complete the Work under this Contract and such Work is ordered, in writing, by the Contract Administrator, the Work or materials shall be considered Extra Work. All Extra Work and any costs related thereto shall be approved by the City Council and agreed to by commencing the Extra Work.

15.2. If a modification or amendment to this Contract increases the amount of Work and the Extra Work or any part thereof is of a type and character that can properly and fairly be classified under one, or more unit price items of the Proposal, then the Extra Work shall be paid according to the amount of Extra Work actually performed and at the applicable unit price. Otherwise, such Extra Work shall be paid for as hereinafter provided.

15.3. Claims for Extra Work will not be paid unless the City authorized the Extra Work in writing. The Contractor shall not have the right to prosecute or take action in court to recover for Extra Work unless the claim is based upon a written Change Order from the City. Payments for Extra Work will be based on an agreed lump sum or on agreed unit prices whenever the City and the Contractor agree upon such prices before the Extra Work is commenced; otherwise, payment shall be a specified percentage allowance as set forth herein.

15.4. For the purpose of determining whether Extra Work proposed will be authorized or for determining the payment method for Extra Work, the Contractor shall submit to the Contract Administrator a detailed cost estimate for proposed Extra Work. The estimate shall show itemized quantities and charges for all elements of direct cost. Charges for the Contractor's extra profit, extra general superintendence, extra field office expenses, bonds and extra overheads shall not be paid except as a percentage addition to the total estimated net cost. Unless otherwise agreed to by the parties, such percentage additions shall be fifteen percent (15%) of the direct costs for the Extra Work performed by the Contractor's own work forces or ten percent (10%) of the direct costs for Extra Work performed by a Subcontractor.

15.5. The payment for Extra Work will be paid as full compensation for the Contractor's and Subcontractor's extra profit, extra general superintendence, extra field office expense, extra overheads and all other elements of extra cost not defined herein as actual field cost.

15.5.1. The actual field cost shall include those extra costs for labor and materials expended in direct performance of the Extra Work and may include:

15.5.1.a. The actual payroll cost of all workmen, such as laborers, mechanics, craftsmen, and foremen.

15.5.1.b. The Contractor's or Subcontractor's net cost for materials and supplies.

15.5.1.c. Contractor owned equipment, which the Contractor has on the job site and which is of a type and size suitable for use in performing the Extra Work shall be used. The hourly rental charges for equipment shall not exceed one-half of one percent (1/2 of 1%) over the latest applicable Associated Equipment Distributors published rental rates.

15.5.1.d. The actual net rental charge for vehicles and construction equipment not owned by the Contractor or Subcontractor and are not available from the equipment of Contractor or Subcontractor.

15.5.1.e. The transportation charges for rented equipment.

15.5.1.f. The charges for extra power, fuel, lubricants, water and special services.

15.5.1.g. The charges for extra payroll taxes, bond premiums and insurance premiums.

15.5.2. The form in which actual field cost records are kept, the construction methods and the type and quantity of equipment used shall be acceptable to the Contract Administrator and shall distinguish Extra Work and work under protest from all other work.

15.6. The Contractor shall file with the Contract Administrator, certified lists in duplicate, of any equipment and the schedule of pay rates for common and semi-skilled labor and operators of various classes, which are intended to be used in performing the Work covered by this Contract. These rates shall be subject to the approval of the Contract Administrator. This information will be used by the Contract Administrator for computation of Extra Work as mentioned above, however, if the Contractor fails to file these lists with the Contract Administrator prior to starting any Work covered by Contract, then the Contract Administrator's computation shall be based on the prevailing hourly rate of wages in the locality for each craft or type of workmen needed to execute the Contract as ascertained by the Oklahoma Labor Commissioner.

16.0 SUPERVISION AND INSPECTION

16.1. The City shall appoint or employ such Contract Administrator(s), Engineer(s) or Inspector(s) as the City may deem proper, to examine and observe the materials furnished and the Work performed, and to see that the said materials are furnished, and that the Work is performed, in accordance with the Plans and Specifications therefore. The Contractor shall furnish all reasonable aid and assistance required by the Contract Administrator, Engineer or Inspector, for the proper examination and observation of the Work and all parts thereof.

16.1.1. Such inspections are for the benefit of the City and shall not relieve the Contractor from any obligation to perform the Work strictly in accordance with the Contract Documents. Any work not constructed in accordance with the Contract Documents shall be removed and made good by the Contractor at his own expense, whenever so ordered by the Contract Administrator.

17.0 CONTROL OF MATERIALS

17.1. The Contract Administrator shall approve the source of supply of each of the materials incorporated into the Work before the delivery of the same is conducted. If requested by the Contract Administrator or the Laboratory representative, preliminary samples of the character and quantity prescribed shall be submitted by the Contractor or producer for examination and tested in accordance with the methods prescribed herein. Only materials proposed to be used may be inspected or tested at any time during their preparation and use. If, after testing it is found that the sources of the supplies, which have been approved, do not furnish a uniform product or if the product from any other source does not meet the Plans and Specifications at any time, the Contractor shall furnish approved materials from other approved sources. No material that has become unfit for use shall be used in the Work even if it was previously approved.

17.1.1. In order to ensure the use of suitable material, the Contract Administrator may require any or all materials to be subject to tests by means of samples or otherwise as determined by the Contract Administrator. The Contractor shall provide such facilities as the Contract Administrator may require for collecting and forwarding samples and shall not make use of or incorporate in the Work any material represented by the samples until the tests have been made and the materials found acceptable and in accordance with the requirements of the Specifications. The Contractor, in all cases shall furnish the required samples without charge.

17.1.2. Within 24 hours after receiving a shipment of material, the Contractor shall advise the Contract Administrator, in writing, of the kind, size, quantity and location thereof.

17.1.3. Where a standard American Society for Testing Materials, American Concrete Institute, American Association of State Transportation Officials or other agency designation is specified for a material, that designation shall be the current revision, either tentative or adopted. If a referenced specification is in disagreement with the Plans and Specifications, the City's Plans and Specifications shall govern.

17.1.3.a. Methods not covered in these publications shall be as approved by the Contract Administrator. In the case of agricultural seeds, samples and test methods shall be as prescribed by the United States Department of Agriculture Current Regulation Announcements.

17.1.4. All materials shall be tested by a Laboratory of good reputation, previously approved by the City. No material shall be accepted for construction unless it bears the approval of the Laboratory. Reports of tests shall be forwarded to the City. Before final acceptance of the project, all parts shall be tested and shall be found in good and proper condition, or shall be placed in such condition.

17.1.5. For the verification of weights or proportions and character of materials and determinations of temperatures used in the preparation of the materials and mixtures, the Contract Administrator, Inspector and Laboratory representative shall have access at all times to all parts

of all concrete plants and other plants furnishing materials for use in the Work.

17.1.6. The Contractor shall facilitate and assist in the verifications of the accuracy of all scales, measures and other devices, which the Contractor operates.

17.1.7. All sieves shall conform to the requirements of the standard specifications for sieves for Testing Purposes, ASTM Designation E11.

17.1.8. The Contractor guarantees that all materials used and all Work done under this Contract, will fully comply with the requirements of the Plans and Specifications.

17.2. Materials shall be stored in order to ensure the protection of their quality and fitness for the Work and shall be located in order to facilitate prompt inspection. All existing materials, which are listed for removal and storage during the progress of the Work shall be carefully removed and stored in the Right-of-Way, at locations determined by the Contract Administrator or at specific locations provided in the Plans and Specifications. That portion of the Right-of-Way not required for Work and travel, unless elsewhere prohibited, may be used for storage purposes and for the placing of the Contractor's plants and equipment, and any additional space required for equipment or new materials shall be provided by the Contractor at the Contractor's expense. Adequate cement storage shall be provided for at least a full day's run.

17.3. All materials not conforming to the requirements of the Plans and Specifications shall be considered defective and all such materials shall be rejected. Unless otherwise permitted by the Contract Administrator such defective materials shall be removed immediately from the site of the Work. No rejected material that has had the defects corrected shall be used until approval has been given by the Contract Administrator. The failure on the part of the Contractor to comply with any order of the Contract Administrator regarding the defective materials shall constitute cause for any defective materials to be removed and replaced and to cause the deduction of the cost of removal and replacement from any amounts due or to become due to the Contractor.

18.0 LEGAL DUTIES AND RESPONSIBILITIES TO THE PUBLIC

18.1. The Contractor warrants that the Contractor is familiar with and shall comply with all federal, state and local laws, statutes, ordinances, rules and regulations and any orders and decrees of any courts or administrative bodies or tribunals in any manner affecting the performance of the Contract, including, without limitation, Workman's Compensation laws, minimum and maximum salary and wage statutes and regulations if applicable, laws with respect to permits and licenses and fees in connection therewith, laws regarding maximum working hours and laws and regulations with respect to the use of explosives. Contractor certifies that the Project, when completed will comply, with the applicable provisions of the Department of Justice implementation plan of Title III of the Americans with Disabilities Act, Title 42 USCA § 12101-12213, as outlined in 28 CFR Part 35; and Contractor further stipulates and agrees to comply with Title VI of the Civil Rights Act of 1964, Title 78 OS § 252.42, USCA § 2000d, *et. seq.*; and if the Work contemplated by this Contract qualifies as a federally assisted program of the Department of Transportation Effectuation of Title VI of the Civil Rights Act of 1964, then Contractor agrees to comply with all requirements imposed by or pursuant to Title 49 CFR Part 21.

18.2. Whenever required, the Contractor shall furnish the City Attorney or the Contract Administrator with satisfactory proof of compliance with said laws, statutes, etc.

18.3. In the hiring of employees for the performance of Work under the Contract the Contractor and any Subcontractor thereunder shall not, by reason of race, color, sex, age, disability, or national origin, discriminate against any citizen of the United States in the employment of laborers or workers, who are qualified and available to perform the Work to which the employment relates.

18.3.1. No Contractor or Subcontractor, nor any person on behalf of either, shall in any manner discriminate against or intimidate any employee hired for the performance of Work under this Contract, on account of race, color, sex, age, disability or national origin.

18.4. The Contractor shall procure all permits and licenses, pay all charges and fees, and give all notices, necessary and incident to the due and lawful prosecution of the Work.

18.5. Without exception, the Bid amounts include all royalties and costs arising from patents, trademarks, and copyrights in any way involved in the Work. It is the intent hereof that whenever the Contractor is required or desires to use any design, device, material or process covered by letters patent, trademark or copyright, the Contractor shall provide for the right to such use by suitable agreement with the patentee, owner or assignee and a copy of such agreement shall be filed with the City; however, whether or not such agreement is made or filed as herein provided, the Contractor and the Surety in all cases shall indemnify and save harmless the City and any affected railroad or railway company or political subdivision from any and all claims for infringement at any time after the award of the Contract.

19.0 CONTRACTOR IS INDEPENDENT CONTRACTOR

19.1. It is expressly agreed that the Contractor is an independent Contractor and is not in any way whatsoever an agent, servant or employee of the City and the City shall in no way or under any circumstance be liable for any acts or omissions, contracts, subcontracts or torts of said Contractor.

20.0 CONTRACTOR'S EMPLOYEES

20.1. The Contractor shall employ competent foremen, experienced mechanics and others skilled in the several parts of the Work given them to do, for performance of the Work contemplated by this Contract; and shall promptly discharge any and all incompetent or otherwise unsatisfactory employees.

20.2. The Contractor agrees that the Contractor (and Contractor's Subcontractors, if any) will not fail or refuse to hire or discharge any individual or otherwise discriminate against any individual with respect to his compensation, terms, conditions or privileges of employees due to consideration of race, color, sex, age, or national origin, and further agrees that it will not (nor will their Subcontractors, if any) limit, segregate or classify Contractor's employees in any way which would deprive or tend to deprive any individual of employment opportunities or otherwise adversely affect Contractor's employee's status as an employee, because of such individual's race, color, sex, age, or national origin. Contractor agrees not to discriminate on the basis of disability if the prospective employee is otherwise qualified to perform the duties of the job. Contractor further agrees that this Contract may be terminated by the City in the event there shall be a violation of any of the provisions of this Section, upon notice in writing, and all claims for monies to become due pursuant to any other provisions of this Contract from the date of termination shall thereafter be forfeited, the Contractor being entitled only to monies expended and services performed and up to and including the date of termination.

20.3. All workmen must have sufficient skill and experience to properly perform the Work in a proper and skillful manner. If any workman is disrespectful, disorderly or otherwise objectionable then that workman shall be discharged by the Contractor or Subcontractor employing such workman, upon written request of the Contract Administrator and shall not thereafter be employed on any portion of the Work without the written consent of the Contract Administrator. Should the Contractor fail to remove such workman the Contract Administrator may withhold all estimates, which are or may become due, or may suspend the Work for each day the Contractor fails to comply with this Section.

20.4. The Contractor shall not sell, sublet or assign any portion of the Contract or Work without the written consent of the Contract Administrator and the granting of any such consent shall not relieve the Contractor of any responsibility under the Contract. The Contractor shall be responsible for the satisfactory settlement by any and all Subcontractors of all claims and obligations arising in connection with the execution of their respective portions of the Contract and for furnishing to the City, to its satisfaction, evidence thereof.

21.0 ASSIGNMENT AND SUBLETTING OF CONTRACT

21.1. The Contractor shall give attention to the fulfillment of this Contract, and shall not let, assign or transfer the Contract or any other rights, titles or interests in or to the same or any part thereof, by attorney

or otherwise, or sublet any part of the Work to any other person without the prior consent of the City in writing.

21.2. Should any Subcontractor fail to perform the Work undertaken by the Subcontractor in a satisfactory manner, then the subcontract shall be immediately terminated by the Contractor upon notice from the City. The Contractor shall be fully responsible to the City for the acts and/or omissions of any Subcontractor and of persons either directly or indirectly employed by any Subcontractor, as the Contractor is for the acts and/or omissions of persons directly employed by the Contractor. Nothing contained in the Contract Documents shall create any contractual relationships between any Subcontractor and the City.

22.0. INDEMNIFICATION AND DEFENSE OF SUITS

22.1. Contractor shall indemnify and hold harmless and defend the City from any and all claims made or actions at law or in equity brought against the City or any of its officers, agents or employees for or on account of the failure, omission or neglect of the Contractor to do and perform any of the covenants, acts, matters or things by this Contract undertaken to be done or performed; or is brought for any injury(ies) or damage(s) caused by negligence or willful act of the Contractor or their Subcontractors or their agents or is brought in connection with any claim or claims based on the lawful demands of the Subcontractors, workmen, material men or suppliers of machinery and parts thereof, or against any equipment, power tools and supplies incurred in the performance of this Contract,

22.1.1. The Contractor shall indemnify and save harmless the City, its officers, agents and employees from all losses, damages, costs, expenses, attorney fees, judgments, or decrees whatever arising out of any such action or suit that may be brought as aforesaid.

22.2. Contractor shall indemnify and hold harmless and defend the City from any and all claims made or actions at law or in equity brought against the City or any of its officers, agents or employees for or on account of any and all injuries or damages alleged to have been received or sustained by any parties by reason of, or arising out of the failure of the Contractor to refill all trenches or ditches, or failure to repair all breaks or failures of said Work, which injuries or damages are alleged to have been received within one (1) year from the final acceptance of the Work hereunder.

22.2.1. Contractor further agrees to pay for any and all judgments that might be rendered against the City in any suits and actions, together with such expenses or attorney's fees expended or incurred by the City in the defense thereof. The Contractor hereby expressly waives any notice that might, by law, be required to be given to the Contractor by the City of any defect, break, settling or failure or of any other condition that might be the cause of injury or damage to any person on account of which the claim or suit was made or filed against the City, or a judgment taken for damages against the City. It is expressly agreed that the acceptance of the Work by the City shall constitute no bar against any person injured or damaged by the failure of the Contractor to perform all of his covenants and agreements hereunder from maintaining an action against the Contractor, or against City from enforcing its rights against the Contractor hereunder.

[The remainder of this page intentionally left blank]

22.3. The City may suspend payments of any sum due or to become due for Work done on this Contract until such claims and/or suits, actions or proceedings are final and liability has been determined. The amount of such damage or liability shall be deducted from sums due or to become due on this Contract. The City will retain the sums mentioned above until the Contractor furnishes evidence that satisfactory settlement has been made. Any action taken by the City shall not excuse the Contractor for failure to perform this Contract or bar the City from legal action to recover from the Contractor the amount of damages or liability suffered in excess of the amount retained.

23.0 WORKER'S COMPENSATION, EMPLOYER'S LIABILITY INSURANCE, OWNER'S RISK AND LIABILITY INSURANCE AND PROPERTY INSURANCE REQUIREMENTS

23.1. The Contractor and their Subcontractors shall obtain and maintain, during the life of this Contract, Workmen's Compensation Insurance as prescribed by laws of the State of Oklahoma and Employer's Liability Insurance.

23.2. Contractor's liability insurance policies shall inure to the benefit of the Contractor as the insured and shall contain an agreement by the insurer to indemnify the Contractor against any and all actions, claims, judgments or demands for damages arising on account of injuries of whatsoever kind and character sustained by a person or persons on account of the construction of this Work or performance of the Contract by the Contractor.

23.3. Where applicable, property damage liability insurance must be endorsed for blasting, the collapse of or structural injury to any building or structure, and damage to underground property, such as wires, conduit pipes, main sewers or other similar property.

23.4. The Contractor shall furnish an owner's liability insurance policy with the City named as an additional insured, issued by the same insurance company as the Contractor's liability coverage, which indemnifies the City and the Engineer(s) against any and all actions, claims, judgments or demands arising out of or on account of injuries of whatsoever kind and character, sustained by any person or persons on account of the construction of the Work or the performance of the Contract by the Contractor. The limits of this coverage shall be as set out in this Contract.

23.5. The Contractor shall obtain and maintain fire insurance policy with extended coverage, vandalism and malicious mischief endorsements upon the site where the Work of this Contractor is to be done, on the completed value form, with one hundred percent (100%) co-insurance. Such insurance shall cover both building and the Contractor as their interests appear.

23.7. Contractor shall provide to the City Certificates of insurance in a form acceptable to the City and shall be filed through the Engineer prior to commencing the Work. The Contractor shall submit the Certificates in duplicate, one original policy or Certificate and one copy of proof of insurance requirements set forth above. The Certificates shall contain a provision that coverage afforded under these policies will not be canceled until at least thirty (30) days written notice has been given to the City. Partial occupancy of the project by the owner shall not affect insurance coverage.

24.0 MINIMUM INSURANCE AMOUNTS

24.1. Owners Liability Insurance minimum coverage limits shall be no less than:

Comprehensive General Liability (with Broad form GCL endorsement)	
Per Accident	\$1,000,000.00
Bodily Injury, per person	100,000.00
Property Damage, per claimant	100,000.00

24.2. Public Liability, other than Automobile minimum coverage limits shall be no less than:

Personal Injury, per person	\$ 100,000.00
Personal Injury, per accident	1,000,000.00
Property Damage, per person	100,000.00
Property Damage, per occurrence	1,000,000.00

24.3. Automobiles and Truck; Owner, Hired and Non-owned minimum coverage limits shall be no less than:

Personal Injury, per person	\$ 100,000.00
Personal Injury, per accident	1,000,000.00
Property Damage, per person	100,000.00
Property Damage, per accident	1,000,000.00

24.4. Employers Insurance minimum coverage limits shall be no less than:

Employers Liability, per accident	\$1,000,000.00
Comprehensive General Liability, per accident	1,000,000.00
Bodily Injury, per accident	1,000,000.00
Property Damage, per claimant	100,000.00

24.5. Railroad Insurance minimum coverage limits shall be no less than:
(Railroad only required when working within the railroad Right-of-Way)

General Liability per accident	2,000,000.00
General Aggregate Limit	4,000,000.00
Automobile Public Liability Insurance, per accident	2,000,000.00

25.0 METHOD AND BASIS OF PAYMENT FOR ITEMS OF WORK

25.1. The Contractor shall be paid for all Work performed under this Contract based on the Contract Administrator's computations of as-built quantities and the Contractor's unit price or lump sum Bid per item. This payment shall be full compensation for: furnishing all supplies, materials, tools, equipment, transportation, labor and services required to do the Work; all loss or damage, because of the nature of the Work, from the action of the elements or from any unforeseen obstruction or difficulty which may be encountered in the performance of the Work and is not specifically provided; all expenses incurred by or because of any suspension or discontinuance of all or any part of the Work; and faithfully completing the Work according to the Contract Documents and the requirements of the Contract Administrator.

25.2. The Contractor, in case of unit-price items, will be paid for the actual amount of Work performed in accordance with the Plans and Specifications as shown by the final measurements.

25.2.1. All Work completed under the Contract will be measured by the Contract Administrator according to United States Standard Measurements. All longitudinal measurements for area will be made along the actual surface of the roadway and not horizontally and no deductions will be made for individual fixtures in the roadway having an area of nine (9) square feet or less. For all transverse measurements for area of base courses and pavements, the dimensions to be used in calculating the pay area shall be the neat dimensions shown on the Plans and Specifications or ordered in writing by the City. All materials, which are specified for measurement by the cubic yard "loose measurement" or "measured in the vehicle", shall be hauled in vehicles approved by the Contract Administrator and measured therein at the point of delivery on the road, unless otherwise provided in the Plans and Specifications. Approved vehicles for this purpose may be of any type or size satisfactory to the Contract Administrator provided that the body of such type that the actual

contents may be readily and accurately determined. All approved vehicles must bear a plainly legible identification mark indicating the specified approved capacity. The Inspector may reject all loads not hauled in such approved vehicles.

25.3. The Contractor, in case of lump sum contracts or lump sum items in a unit price contract, will be paid for the actual amount of Work performed in accordance with the Plans and Specifications as shown by the final measurements.

25.3.1. All Work completed under lump sum items in the Contract will be determined by the Contract Administrator. Major items of work in a lump sum contract and the cost therefore will be identified at the beginning of the Work. Pay estimates will then be computed based on the portion of each item completed, as determined by the Contract Administrator. The sum of all Work completed on all items of work will constitute the basis of payment.

25.4. The City shall pay the Contractor for Extra Work in the following manner:

25.4.1. An amount to the sum of: (1) the Contractors (or Subcontractors) Direct Cost (as defined below) in performing such Extra Work and (2) ten percent (10%) thereof for all Extra Work performed pursuant to the Terms and Conditions of this Contract. Provided that payment can be authorized only to the extent authorized by law.

25.4.2. Direct Costs means and includes: (1) all payments for wages and other labor costs incurred in performing the Extra Work; (2) the cost of all materials used or consumed in performing the Extra Work and including any sales, use, or excise taxes required by law to be paid with respect to such materials being delivered to the site of the Work; (3) all taxes and insurance and bond premiums paid as a percentage of the aforesaid wages; and (4) allowances for the use of equipment in the performance of the Extra Work, at the rates set forth in the latest edition, published prior to the opening of Bids for this Contract of the Compilation of Rental Rates for Construction Equipment, prepared by the Associated Equipment Distributors. When any piece of equipment is used on any Extra Work job for three (3) days or less, the daily rates set forth in the Compilation of Rental Rates for Construction Equipment shall apply; when used for more than three (3) days and less than twenty-two (22) days, the weekly rates shall apply and when used more than twenty-one (21) days, the monthly rates shall apply. When a weekly rate is applied to a period of over seven (7) days, the rate for the excess days shall be one-seventh of the weekly rate. When a monthly rate is applied to a period of over thirty (30) days, the rate for the excess days shall be one-thirtieth (1/30) of the monthly rate.

25.4.3. If the wages paid by the Contractor for any Extra Work include any premium pay (i.e. anything over straight-time rates) for overtime, Sunday or holiday work, and the like, the amount of all such premiums shall be deducted from the Direct Costs for the purpose of calculating the aforesaid allowance of ten percent (10%). Said allowance is to cover profit and all costs of the Extra Work for which reimbursement is made, including superintendence, overhead and use of tools and equipment for which no specific allowance is made.

25.4.4. At the end of each day, the Contractor and Contract Administrator shall check and verify records of payrolls for labor furnished for Extra Work on that day. Each invoice for Extra Work shall be in form satisfactory to the Contract Administrator and shall be submitted to the Contract Administrator by the Contractor in quadruplicate. Attached to each invoice shall be the original receipted bills and invoices covering the costs of all materials, including freight and haulage charges, which are used or consumed in performing the Extra Work. An invoice for each Extra Work job shall be submitted not later than the 20th day of each month following any of the Extra Work that was actually performed. The City shall retain ten percent (10%) of all Extra-Work payments until the final completion and acceptance of the Work.

26.0 ADMINISTRATIVE COSTS AND FEES

26.1. In the event the improvements are to be paid for in cash the costs and fees for publication, engineering, filing, recording, abstracting, acquisition of easements, and City water (where available) for flushing and pipe testing shall be paid by the City unless otherwise provided for in the Contract Documents.

27.0 PAYMENTS

27.1. If the Work is progressing in a satisfactory manner on or about the first day of each month, the Engineer will prepare an estimate for a partial payment of the Work completed after receiving a written request from the Contractor by the first day of the month. An estimate for partial payment shall include items actually incorporated in the Work and may include materials acceptable to the Engineer that are delivered to the Work site, provided the Engineer is furnished duplicate copies of actual manufacturer's invoices of material to be included in the estimate. The estimate shall be submitted to the Director of Engineering and Construction who shall either authorize payment or notify the Contractor in writing of the reason payment has been delayed or denied; this payment or notice shall be mailed no later than one month following receipt of the estimate.

27.1.1. Partial payments will be made to the Contractor in accordance with the following schedule:

27.1.1.a. In the amount of 95 percent (95%) of the value of the Work completed.

27.1.1.b. If the Contractor has performed satisfactorily and the Work is substantially complete (operational or beneficial occupancy) the withheld amount may be reduced to only that amount necessary to assure completion.

27.1.1. c. In addition to the conditions set forth in a and b above, payments will always be less any sums that may be retained or deducted by the City under the terms of any of the Contract Documents and less any sums that may be retained to cover monetary guarantees for equipment, materials or process performance.

27.1.2. The Contractor may withdraw any part, or the whole, of the amount which has been retained from partial payment to the Contractor pursuant to the terms of Contract, upon depositing with or delivery to the Director of Engineering and Construction one of the following:

27.1.2.a. United States Treasury Bonds, United States Treasury Notes, United States Treasury Bills in an amount equal to the amount of the retainage withdrawn, or

27.1.2.b. General Obligation Bonds of the State of Oklahoma in an amount equal to the amount of the retainage withdrawn, or

27.1.2.c. Certificates of Deposit in an amount equal to the amount withdrawn from the retainage from a state or national bank having its principal office in the State of Oklahoma. No retained amount shall be withdrawn, which would represent an amount in excess of the market value of the securities at the time of deposit or of the per value of such securities, whichever is lower.

27.1.3. All materials and Work included in partial payments shall become the property of the City and materials included in a partial payment shall not be removed from the Work site. However, this provision shall not be construed as relieving the Contractor of responsibility for the care and protection of the materials and Work for which payments have been made; or does it relieve the Contractor from being required to restore any damaged Work, or materials removed from the Work site by unknown parties and it is not a waiver of any of the Terms and Conditions of the Contract.

27.2. Final payment will be made when the Work has been completed. The Engineer shall carefully measure and determine the as-built quantities of each class of Work as shown on the schedule of Bid items and such Extra Work performed by order of the Engineer. The aggregate cost of the Work done and the materials furnished shall constitute the amount due for the completed Work. All prior estimates and payments shall be subject to correction in the final estimate and payment.

28.0 RELEASE OF LIABILITY AND ACCEPTANCE

28.1. The acceptance of the final payment by the Contractor shall operate as and shall be a release to the City, its officers, agents and employees thereof, from all claims and/or liability from the Contractor for anything done or furnished by the City relating to or affecting the Work or for any act or negligence by the City, its officers, agents and employees relating to or affecting the Work. No person, firm or corporation other than the Contractor as a party to this Contract will have any interest hereunder, and no claim shall be made or be valid and neither the City, its officers, agents nor employees shall be liable or be held to pay any additional money.

28.2. It shall be the duty of the Contract Administrator to determine when the Work is complete and the Contract fully performed and to recommend its acceptance by the City. The Work herein specified to be performed shall not be considered finally accepted until all the Work has been accepted by the City.

29.0 PAYMENT OR ACCEPTANCE NOT A WAIVER BY CITY

29.1. Neither acceptance by the City, the Contract Administrator or any employee of either, nor any order by the City for the payment of money or the actual payment thereof, nor any taking of possession by the City, nor the granting of any extension of time, shall operate as a waiver of any rights or powers, whether by Contract or by laws, of the City. In the event that after the Work has been accepted and final payment made, it is discovered that any part of this Contract has not been fully performed or has been done in a faulty or improper manner, the Contractor shall immediately remedy such defect. In the event that the Contractor neglects to remedy any such defect within a reasonable time after written notice thereof, the Contractor shall be liable for and shall pay to the City the costs of remedying such defect, or a sum equal to the damage caused thereby, or both, as the City may elect. The acceptance of the Work or final payment therefore shall be no bar to claim or suit against the Contractor or Surety, or both.

29.2. Upon the satisfactory completion of all Work required under the Contract, the Contract Administrator shall certify to the City, in writing, the total amount of Work performed and compensation earned by the Contractor. No unauthorized Work shall be included or paid for. Within thirty (30) days, upon receipt of said certification, the City shall make full payment to the Contractor, less the total of all partial payments in accordance with the Terms and Conditions for final payment. Provided, however, that before making final payment of the full amount earned by the Contractor, the City may require the Contractor to furnish satisfactory evidence that the Contractor and his Subcontractors have paid all of their payrolls, bills, expenses and costs of every type and nature whatsoever connected with the performance of the Contract. The acceptance by the Contractor of final payment shall operate as a release to the City from claims and liabilities of every type and nature owing to the Contractor in connection with the performance of the Contract. The date of the Contract Administrator's approval by will be the date of acceptance of the Work.

[The remainder of this page intentionally left blank]

30.0 CONTRACTOR'S OBLIGATION AFTER ACCEPTANCE

30.1. Contractor agrees, without cost other than is specially provided for in this Contract, that at any and all times during one (1) year next following the completion and final acceptance of the Work performed under this Contract and without notice from the City, to refill all trenches or ditches that may sink or settle, to

repair all breaks or failures that may occur in the Work due to defective material or workmanship.

31.0 CONTRACTOR'S WARRANTIES AND GUARANTIES

31.1. The Contractor warrants and guarantees that all materials used in the Work will conform to the Plans and Specifications and that all Work will be performed in a proper and workmanlike manner and in accordance with the Contract.

32.0 LAWS AND ORDINANCES

32.1 This Contract shall be construed under the laws of the State of Oklahoma and jurisdiction shall be in the County where the Work is performed and the Work site property is located.

32.2. The Contractor is obligated to keep fully informed of all existing and current regulations of the City, County, State and Federal laws, which in any way limit or control the actions or operations of those engaged upon the Work or affecting the materials supplied to or by it. The Contractor shall at all times observe and comply with all applicable ordinances, laws and regulations; and shall protect and indemnify the City, its officers, agents and employees against any claims or liability arising from or based on any violation of the same. All such applicable laws and ordinances are a part of this Contract as though fully set forth herein.

33.0 IMMIGRATION COMPLIANCE

33.1 Contractor shall demonstrate that he:

33.1.1 Has complied, and shall at all times during the term of this Contract, comply in all respects with all immigration-related laws, statutes, ordinances and regulations including without limitation, the Immigration and Nationality Act, as amended, the Immigration Reform and Control Act of 1986, as amended, and the Oklahoma Taxpayer and Citizen Protection Act of 2007 (Oklahoma HB 1804) and any successor laws, ordinances or regulations (collectively, the Immigration Laws"); and

33.1.2 Has properly maintained, and shall at all times during the term of this Contract, maintain any and all employee records required by the U.S. Department of Homeland Security ("DHS"), including, without limitation, properly completed and maintained Form I-9s for each of the Contractor's employees; and

33.1.3 Has verified the employment eligibility for all employees hired on or after July 1, 2008 through DHS's E-Verify system, and shall at all times continue to verify the employment eligibility of all employees hired during the term of this Contract; and

33.1.4 Has required, and will at all times during the term of this Contract, require any sub-contractor utilized, hired or sub-contracted for by Contractor for the completion or undertaking of any duties, tasks or responsibilities under this Contract, to comply the requirements and obligations imposed by the Immigration Laws and set forth in Paragraph (I), parts (a), (b) and (c), above, with regards to each of the sub-contractor's employees.

33.2. Contractor will indemnify, defend and hold harmless City against any loss, cost, liability, expense (including, without limitation, costs and expenses of litigation and reasonable attorney's fees) demands, claims, actions, causes of action, liabilities, suits, damages, including special and consequential damages that arise from or in connection with, directly or indirectly, Contractor's failure, deliberate or negligent, to fulfill its obligations and representations regarding verifying the employment eligibility of its employees and the employees of any subcontractor utilized by Contractor as set forth more fully in Paragraph 33.1 above.

34.0 NOTICES

34.1. Any notices or other communications hereunder may be given to Contractor at the address given in their Proposal, to the Surety at the office of the Attorney-in-Fact signing the Contract or at Surety's home office address on file with the Insurance Commissioner of the State of Oklahoma and to the City in care of the Contract Administrator or at such place as may be otherwise designated in writing. The personal delivery at such address, or depositing in any United States mail box regularly maintained by the Post Office, of any notice, letter or other communication to the Contractor or the City, shall be deemed sufficient service thereof, and the date of said service shall be the date of such personal delivery or mailing.

34.2. Any address may be changed at any time by an instrument in writing, executed by the Contractor or the Surety and delivered to the Contract Administrator. Nothing herein contained shall be deemed to preclude or tender inoperative the service of any notice, letter or communication upon the Contractor personally.

35.0 SECTIONS AND PARAGRAPH CAPTIONS

35.1. The Section and paragraph captions and headings are not a part of the Contract Documents. They are included for convenience only and are not to be considered in the interpretation of the Contract Documents. Said captions and headings are mere labels, intended as aids in locating and reading the various portions of the Contract Documents.

36.0 CONTRACT BINDING ON THE PARTIES

36.1. Except as otherwise expressly limited herein, this Contract shall be binding upon the parties and their respective heirs, representatives, successors or assigns.

[The remainder of this page intentionally left blank]

IN WITNESS WHEREOF, the City Manager of the City of Broken Arrow, Oklahoma has hereunto set his hand, for and on behalf of the City of Broken Arrow and the Contractor has signed, or caused his name to be signed, and seal affixed by proper authority, the day and year first above written and these presents have been executed in triplicate counterparts.

OWNER:

City of Broken Arrow, a Municipal Corporation

Approved as to form:

By [Signature]
Assistant City Attorney

By [Signature]
Michael L. Spurgeon, City Manager

Date 12/21/23

Attest:

[Signature]
City Clerk
Date 12.21.2023



CONTRACTOR NAME:

Momentum Services LLC
(Printed company name)

By [Signature]
Brian A. Humberger owner/managing member
(Printed name and title)

Date 12/15/2023

(CORPORATE SEAL) if applicable

Attest _____

(Printed name and title)

Date _____

VERIFICATION

State of OK
County of Tulsa

Before me, a Notary Public, on this 15th day of December, 2023, personally appeared Brian Humberger, known to be to be the (President, Vice-President, Corporate Officer, Member, Partner, or Other: managing member of Momentum Services LLC (Company name), and to be the identical person who executed the within and foregoing instrument, and acknowledged to me that he executed the same as his free and voluntary act and deed for the uses and purposes therein set forth.

My Commission Expires:
10-27-2024

[Signature]
Notary Public



SECTION V.
GENERAL SPECIFICATIONS

**DIVISION I
CONTROL OF EQUIPMENT**

(General): All equipment necessary for completion of the Work contemplated under this Contract shall be in first-class operating condition and shall have been inspected and approved by the Contract Administrator before construction where the equipment is used will be permitted to begin. Thereafter, the equipment shall be maintained in first-class operating condition throughout its use for the Work under this Contract.

[The remainder of this page intentionally left blank]

DIVISION II
CONSTRUCTION SPECIFICATIONS

All Work shall be accomplished in accordance with ODOT, EPA, and ODEQ regulations, AWWA Standards and City of Broken Arrow Codes and Standard Construction Specifications.

[The remainder of this page intentionally left blank]

**DIVISION III
MATERIAL SPECIFICATIONS**

All materials shall be in accordance with materials as specified in the City of Broken Arrow Standard Construction Specifications.

[The remainder of this page intentionally left blank]

**DIVISION IV
SPECIAL PROVISIONS**

SP 1.0 PURPOSE: It is the intent that a contract will be executed by the City of Broken Arrow, Oklahoma (hereinafter referred to as the "CITY") and by the successful bidder (hereinafter referred to as "CONTRACTOR") for labor, materials, and equipment to complete the said project that is a public facility of the CITY. This contract will include, by reference and incorporation, the contract bid proposal, instructions to bidders, specifications, and all other documents contained in the bid packet. All actions, duties, and obligations required by the CONTRACTOR apply only to the CONTRACTOR's agents and employees. All legal protections offered to the City of Broken Arrow shall also be extended to any CITY entity involved with this contract.

SP 2.0 FIELD OFFICE: This is not required on this project.

SP 3.0 PHOTOGRAPHS: They are required on this project.

SP 4.0 STANDARD SPECIFICATIONS:

4.1 City of Broken Arrow Standard Construction Specifications dated August 19, 1999.

4.2 The Oklahoma Department of Transportation (ODOT) Standard Specifications for Highway Construction dated 2009, Sections 200 through 800 are included by reference. Specifications listed in the contract as ODOT XXX.XX Description, where XXX.XX represents a specification number, refer to the current ODOT Standard Specification with the same number. Where references are made to ODOT as the agency contracting for the work, the reference will be read as "City of Broken Arrow" for City of Broken Arrow contracts. References to Engineer will be read as Contract Administrator for City of Broken Arrow contracts.

SP 5.0 CERTIFICATION: The CONTRACTOR shall furnish certification from the manufacturer that all materials meet applicable specifications. Copies of material certification shall be furnished to the City Engineer prior to installation or incorporation of material in the work.

SP 6.0 TAXES: This project is exempt from state and local sales tax.

SP 7.0 EQUIPMENT: Equipment and tools necessary for handling materials and performing all parts of the work shall be the responsibility of the CONTRACTOR as to design, capacity, and mechanical condition. The equipment shall be at the job site sufficiently ahead of the start of construction operations.

SP 8.0 STORAGE OF SUPPLIES AND EQUIPMENT: The CONTRACTOR shall be responsible for storing his supplies and equipment. CITY maintenance yards shall not be used for these purposes. However, equipment may be left parked on CITY right-of-way provided there is at least a 10-foot clear zone between the white travel edge line and the nearest portion of the equipment. The CITY shall not be liable for the CONTRACTOR's equipment in any way, or liable for any claims arising from incidents involving said equipment, while this equipment is parked upon CITY right-of-way. CONTRACTOR may use facility area for material storage but will need to coordinate with Plant Manager as well as Contract Administrator. CONTRACTOR shall minimize roadway area used as much as possible and shall minimize damage to the existing roadway surface (rubber tire vehicles preferred to tracked vehicles on existing asphalt). If additional laydown area is required, CONTRACTOR may need to negotiate with adjacent landowners.

SP 9.0 PAY ITEMS INCLUSIVE: Most contractual pay items should correspond with similar pay items used on CITY construction projects. However, some contractual items are more inclusive of size variations, in an attempt to avoid a lengthy bid sheet.

SP 10.0 MOBILIZATION: Mobilization included in contract.

SP 11.0 TIME RESTRICTIONS: CONTRACTOR should be aware of construction time restrictions on this project are from 7:00 A.M. – 7:00 P.M.

SP 12.0 CONTRACTOR'S PERSONNEL:

12.1. The CONTRACTOR's employees shall be identified with the name or logo of the CONTRACTOR. The CONTRACTOR's employees, officers, agents, and subcontractors shall at no time identify themselves as being employees of the CITY.

12.2 All drivers of the CONTRACTOR's equipment shall at all times possess and carry a valid and proper driver's license.

12.3 The CONTRACTOR's employees shall be properly trained and professional in the performance of their duties. The CITY may require that the CONTRACTOR remove from the job employees who endanger persons or property, display impolite and socially unacceptable behavior, or whose continued employment under this contract is inconsistent with the interest of the CITY and/or the public.

12.4 All of the CONTRACTOR's employees shall be U.S. citizens or legal aliens.

SP 13.0 TECHNICAL SPECIFICATIONS: See attached Technical Specifications.

SP 14.0 NOT USED

SP 15.0 PROGRESS SCHEDULE: Contractor is required to provide a progress schedule as set out in the Standard Contract Terms and Conditions.

SP 16.0 WATER FOR CONSTRUCTION:

Water will be provided via the nearest City of Broken Arrow hydrant at no cost to the Contractor. The Contractor will be responsible to obtain a Construction Meter from the City, paying a \$1,200 escrow deposit for use of the meter. The escrow money will be returned to the contractor when the construction meter is returned. Failure to return the meter within 2 working days after the Contract Administrator determines the meter is no longer required on the project could result in water charges, loss of some or all of the escrow deposit and contractor earnings withheld. Contractor is responsible for any damages to meter or hydrant he may cause. Contractor is responsible for transport and distribution of water as needed.

SP 17.0 COORDINATION OF DRAWINGS AND SPECIFICATIONS:

These Project Drawings, Technical Specifications, and all supplementary documents are essential parts of the Contract and a requirement in one is as binding as if in all. The City intends them to be complementary and to describe a complete Contract. In case of discrepancy between these Contract documents, the order of precedence is as follows: (1) For Information, Technical Specifications over Drawings; (2) For Dimensions, Project Drawings over Specifications. Project Drawings and Specifications both take precedence over supplementary documents.

SP 18.0 NOT USED

SP 19.0 NOT USED

**SECTION VI.
BOARD UP PROCEDURES
(US FIRE
ADMINISTRATION)
SPECIFICATIONS**

U.S. Fire Administration

**National Arson
Prevention Initiative**



**BOARD UP
PROCEDURES**

STOP the use of empty buildings as targets for arsonists, as crack houses, as hang outs for gangs, as garbage dumps, and as temporary shelters for the homeless.

These procedures are intended to protect buildings that are temporarily vacant pending rehabilitation and use.

"HARDENING THE TARGET" BOARD UP PROCEDURES

Protecting valuable buildings from the weather and from illegal entry can be accomplished by improving security, organizing block watches, improving lighting, periodic patrols, and by following these directions.

1. DISCONNECT ALL UTILITIES AT THE STREET

- A. Turn off water at the street and drain the system to its lowest point. Leave faucets open and put anti-freeze in all traps containing water.
- B. Have the utility company disconnect electricity at the street and remove and cap meters.
- C. Shut off LNG supply at the street. Disconnect and remove LPG and heating oil tanks.

2. REMOVE ALL FLAMMABLES AND COMBUSTIBLES FROM INSIDE AND OUTSIDE THE BUILDING

- A. Remove all upholstered furniture, combustible materials and trash from the building, including the basement and attic.
- B. Remove trash and trash containers and combustible furniture from exterior stairwells, porches, fire escapes and outbuildings.
- C. Remove shrubbery and vegetation that could support or spread a fire.

3. SECURE THE BUILDING TO PREVENT ENTRY

- A. Search the entire building to ensure that it is unoccupied.
- B. Remove doors and storm windows and place in storage.

DETERMINING HOW MUCH PROTECTION IS NEEDED

1. Openings in the basement, first floor doors and windows and any point of entry accessible from a porch, fire escape or other potential climbing point require additional security measures. These openings should be barricaded with plywood, 2x4s, bolts and nails.

2. Openings that are at least 10' from ground level which are not accessible from a porch, fire escape, roof, or other climbing point can be secured with nails in each brace, and every 12" around the perimeter. For these openings the plywood should be fitted so that it rests snugly against the exterior frame, butting up to the siding on wood frame buildings and up to the brickwork on brick buildings. It may be necessary to remove the staff bead so this fit can be flush and tight.

BOARDING UP

1. Cut plywood to fit over the window and door openings, flush with outside of the molding.

Note: For buildings with metal door and window frames the alternative is to cut the plywood and 2x4s to fit the inside of the door frame buffed up against the band molding.

2. Cut the 2x4s to fit the horizontal dimension of the plywood. You will need two 2x4 exterior and two interior braces for each window and three sets for each door.

For buildings with metal doors and window frames the 2x4s for the outside will be cut to the dimensions of the plywood, fitting inside the door frame, against the band molding. For the inside the 2x4s will be cut to the outside dimension of the door or window frame.

3. Pre drill 3/8th inch holes in the plywood and the braces.

4. The holes will be placed approximately 1/3 of the length of the brace from each outside edge of the door and window jam.

5. The two window braces will be placed 1/3 of the distance from the top and the bottom of the window.

6. The three door braces will be placed; one in the center of the doorway, and one half the distance from the center to the top and to the bottom of the doorway.

7. Place the plywood over the exterior opening and nail to the frame.
For metal frames place the plywood and braces inside the frame against the band molding.

8. Place the 2x4 braces over the interior and exterior of the door or window.

9. Place the large washer over the carriage bolt and place the bolt through the holes.

10. Place washer and nut inside and tighten securely. Torque the nut so that it slightly compresses the interior 2x4.

After all entrances are secured, the interior worker should exit the building, using a ladder, through a window, if such exists, at least 10 feet above the ground. Nail or screw a plywood sheet over the worker's exit. Patrol the building periodically to check the security.

NOTE: USE ROUNDED HEAD

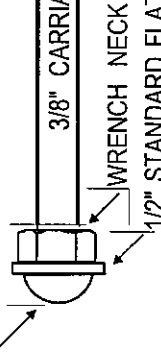

WASHER &
3/8" COURSE CONSTRUCTION GRADE NUT

MATERIALS NEEDED

- A. 1/2" plywood, grade CDX and 2" x 4" by 8' construction grade lumber.
- B. 3/8" by 12" carriage bolts (rounded head on weather side).
- C. 3/8" construction grade nuts.
- D. Flat washers with an inside diameter large enough to bypass the wrench neck inside the carriage bolt head so no lift edge is available beneath an installed carriage bolt head.
- E. 1/2" diameter flat washers for installation beneath the nut inside the building.
- F. 1-5/8" (6d) galvanized or stainless steel ring-shank nails or comparable deck nails.

WINDOWS

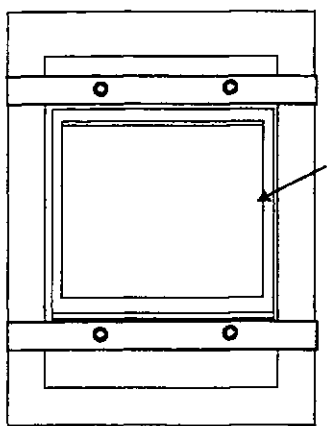

Windows raised and lowered to center of the frame

View from inside bldg.

Note: Outside view of window is same as view from outside door except with two 2x4 braces instead of three.

DOORS

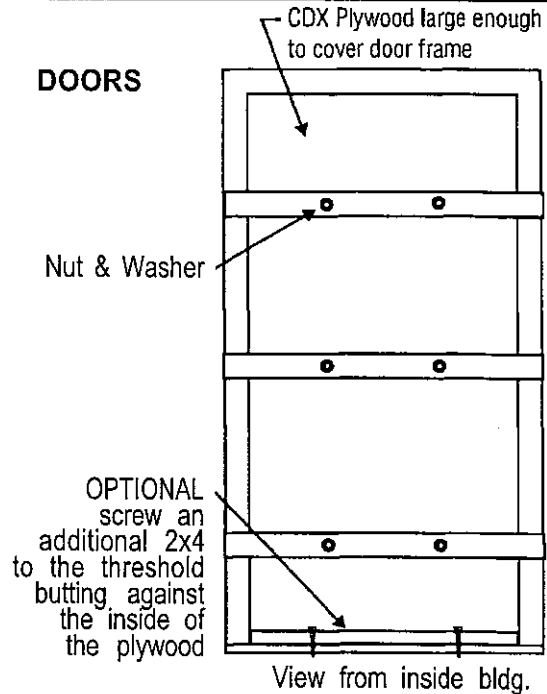

View from inside bldg.

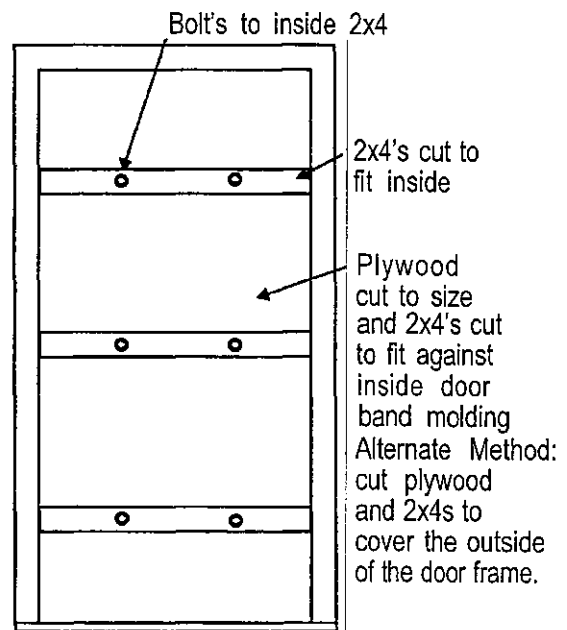

View from outside bldg



To request arson prevention materials:

**National Arson Prevention Clearinghouse
16825 South Seton Avenue,
Emmitsburg, Maryland 21727
1-888-603-3100**

Materials available include:

- General Arson Prevention Literature
- Video: Fighting Church Arson
- Church Arson Prevention Literature
- Arson Prevention Brochures
- Juvenile Firesetter Brochures
- Coalition Building Handbook
- Arson Threat Assessment Guides for:
Communities, Churches, Buildings
- Information on Arson Classes and
Courses delivered by the National
Fire Academy



