

EXHIBIT "A" EASEMENT CLOSURE

OWNER:

Harper, Bobby Wayne and Kathleen E.

PROPERTY ID:

78155-84-22-09430

PROPERTY ADDRESS:

917 West Boston Street

STATEMENT OF BEARINGS

Basis of Bearings: Amended Plat of Arrow Park Addition, Plat No. 3284.

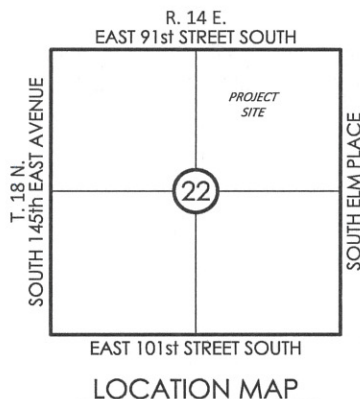
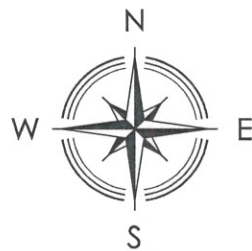

LINE	BEARING	DISTANCE
L1	S 00°00'00" E	34.92'
L2	N 90°00'00" W	6.00'
L3	S 00°00'00" E	33.80'
L4	N 90°00'00" W	4.00'
L5	N 00°00'00" W	33.80'
L6	N 90°00'00" E	4.00'

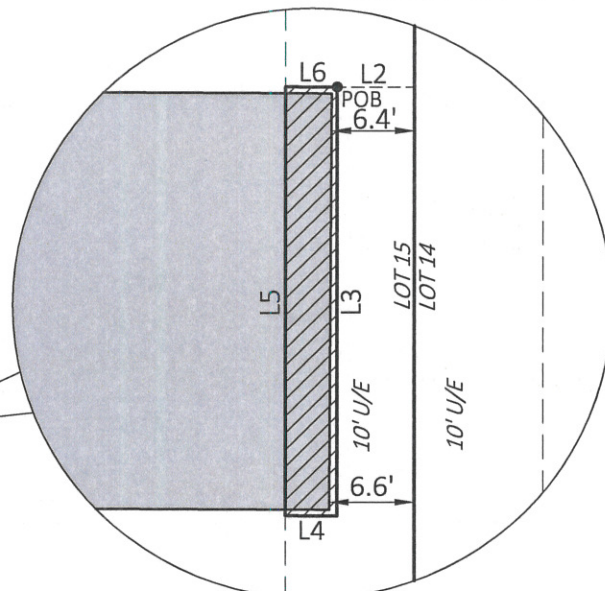
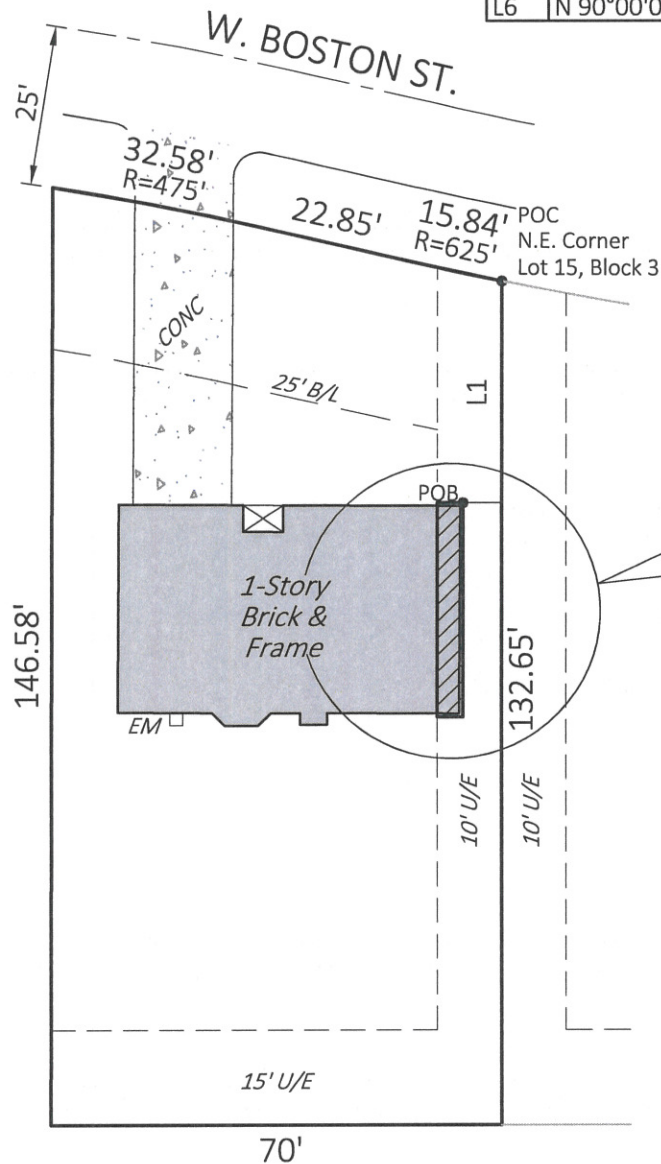

LEGEND

- POB POINT OF BEGINNING
- POC POINT OF COMMENCEMENT
- Easement Closure
135.20 s.f. or 0.003 acres, more or less

Lot Fifteen (15), Block Three (3), AMENDED PLAT OF ARROW PARK ADDITION to the City of Broken Arrow, Tulsa County, State of Oklahoma, according to the recorded plat there of and being more particularly described as follows:

COMMENCING at the Northeast corner of said Lot 15; thence South 00°00'00" East and along the East line of said Lot 15, for a distance of 34.92 feet; thence North 90°00'00" West and perpendicular to said East line, for a distance of 6.00 feet to the POINT OF BEGINNING; thence South 00°00'00" East and a parallel with said East line, for a distance of 33.80 feet; thence North 90°00'00" West and perpendicular to said East line and parallel with the South line of said Lot 15, for a distance of 4.00 feet; thence North 00°00'00" West and parallel with said East line, for a distance of 33.80 feet; thence North 90°00'00" East and perpendicular to said East line and parallel with said South line, for a distance of 4.00 feet the POINT OF BEGINNING.

NATHANIEL J. REED
 License # 1744
 Nathaniel J. Reed
 Oklahoma Professional Land Surveyor #1744

Date 6-23-2017



HARDEN & ASSOCIATES
 SURVEYING AND MAPPING, PC
 5807 South Garnett Road, Suite K (918) 234-4859 Office
 Tulsa, Oklahoma 74146 (918) 437-5551 Fax
 Certificate of Authorization No. 4656 Expires June 30, 2017

PARCEL: EASEMENT CLOSURE	PROJECT No.: 171032
DRAWING: PARCEL 1.0	DATE: JUNE 2017
REVISION:	DRAWN: JLN
	SCALE: 1:30'
	CHECKED: NJR
	SHEET NO.: 1 OF 1

Deed Name: Parcel 1.0

Starting Coordinates: Northing 362690.57, Easting 2623462.37

Bearing	Distance	Type	Radius	Arc Len	Delta	Tangent	Description
S 00°00'00" E	33.80	LINE					
N 90°00'00" W	4.00	LINE					
N 00°00'00" W	33.80	LINE					
N 90°00'00" E	4.00	LINE					

Ending Coordinates: Northing 362690.57, Easting 2623462.37

Area: 135.20 S.F., 0.0031 Acres

Total Perimeter Distance> 75.60

Closure Error Distance> 0.0000 Error Bearing> N 90°00'00" E

Closure Precision> 1 in 8433846205.5