

Contract Change Order # 1

Project Name: City Hall Renovation Entry Plaza Planter Walls Project Number: 151703B
 Project Location: City of Broken Arrow - City Hall Date of Application: Wednesday, October 12, 2016
 Contractor: Magnum Construction Submitted By: Robert Catcher

Summary of Change in Scope of Work

The following scope of work consisting of work location, work description, established quantities, and timeline for completion has been reviewed and agreed upon by the contractor, the origin funding department, and the Engineering and Construction Department.

Change of Work Items Included in this Change Order:

- 1) Install Granite façade on the southern stairwell walls as noted in the attached plans. Proposal to include installation complete in place.

Change in Contractual Project Time:

- 1) No additional time is required for this change.

Plan Sheets or Additional Documents Attached: Yes No Other: EPS proposal and plans

Work Order Quantities

Item#	(Spec)	Item Description	Units	Price	Quantity	Total Amount
CO1-1	-	Additional Granite façade	LS	\$ 18,600.00	1	\$ 18,600.00
						\$ -
						\$ -
Total Change Cost:						\$ 18,600.00

Summary of Project Costs

Total Previous Change Orders:	\$ -	Original Contract Amount:	\$ 140,225.00
Current Change Order:	\$ 18,600.00	Amended Contract Amount:	\$ 158,825.00
Total Cost of Change Orders:	\$ 18,600.00	Percent Change in Contract:	13.26%
Total Cost Applicable to CBA:	\$ 18,600.00	Percent Change Applicable to CBA:	13.26%

Change Order Authorization

Change Order # 1 in the sum of: \$ 18,600.00 has been reviewed by all parties and is recommended for approval by:

Contractor Submitting Change Order:	<u>Clinton W. Redwine</u> Name	<u>[Signature]</u> Signature	<u>10.12.16</u> Date
Construction Division Manager:	<u>Timothy S Robins, PE</u> Name	<u>[Signature]</u> Signature	<u>10/12/16</u> Date
Director of Engineering & Construction:	<u>Alex Mills, PE</u> Name	<u>[Signature]</u> Signature	<u>10/13/16</u> Date
Assistant City Manager - Operations:	<u>Kenneth D Schwab, PE</u> Name	<u>[Signature]</u> Signature	<u>10/14/16</u> Date
City Manager:	<u>Michael Spurgeon</u> Name	<u>[Signature]</u> Signature	<u>10/14/16</u> Date

This Change is Executed Through:

- This change to the contract documents is authorized by the City Manager's authority in accordance with the applicable state statutes and COBA Code of Ordinances.
- This change to the contract documents was approved at the City Council/BAMA meeting held on : _____



P.O. Box 707
Broken Arrow, OK 74013

October 11, 2016

Project: City Hall Entry Plaza Planter Walls
City of Broken Arrow
220 S 1st Street

Proposal Request No. 1

Install additional granite cladding and wall cap at Southeast stair riser. Remove and reinstall existing handrails once new granite is installed. Pricing is dependant on approval prior to completion of original scope of work. Remobilization will result in an additional \$3,300.00 added to this proposal.

add \$ 18,600.00

Note:

A handwritten signature in blue ink, appearing to read "Robert Catcher", is written over a horizontal line.

Robert Catcher
Project Manager

CONSTRUCTION COST ESTIMATE BREAKDOWN

DESCRIPTION OF WORK TO BE PERFORMED:
Install additional granite at front entrance

LINE NO.	ITEM	QUANTITY	UNIT OF MEASURE	MATERIAL COST		LABOR COST		EQUIPMENT		OTHER COSTS		SUB	MCI TOTAL
				UNIT	TOTAL	UNIT	TOTAL	UNIT	TOTAL	UNIT	TOTAL		
	Granite	1.00	LS	-	0.00	-	0.00	-	0.00	-	0.00	0.00	14,000.00
	Modify Handrails	1.00	LS	-	0.00	-	0.00	-	0.00	-	0.00	500.00	500.00
	SUBTOTAL				0.00		34.99%		0.00			14,500.00	14,500.00
					0.00%		0.00						0.00
TOTAL DIRECT COST													14,500.00
G&A													1,450.00
Profit													15,950.00
Bond													18,343.00
TOTAL													18,618.00
													18,600.00

BY:  Robert Catcher - Project Mgr. Additional time required for this change -----N/A Days

**CHANGE ORDER
REQUEST**

PROJECT: 151703B - City Hall Renovations - Entry Plaza Planter Walls
Broken Arrow, OK
Scope: Exterior Stone
To: Robert Catcher
Magnum Construction, Inc.
(918) 227-2530

Change Order Request: [001]
Date: 10/10/2016

Elevated Paver Systems will supply, except as noted, all material, labor, supervision and equipment for the installation of the additional stone veneer at the wall south of the southernmost entry stairs. All quantities are based on attached drawing markup dated 10/10/2016.

Scope of Work

EPS will provide all exterior stone cladding to match the new planter walls/caps. We have included all necessary mechanical anchoring systems, mortar setting beds, and joint sealants. Cladding is bid in the Absolute Raindrop Black color with a honed finish.

Clarifications & Bid Assumptions

1. This proposal will be listed as part of the contract documents.
2. All demolition work is by others.
3. All concrete work, substrate repair or otherwise, is excluded.
4. All appurtenances (handrails, custom planters, benches, lights, etc.) are excluded.
5. We have assumed a this work can be completed while currently on-site. If an additional mobilization is required, please add \$3,300 to the pricing below.
6. We have estimated 5 working days to complete the scope of work outlined above.
7. Sales tax is excluded.
8. Davis-Bacon or any other wage determination is not a consideration on this project.
9. Costs of permits, if required, are excluded.
10. A payment and performance bond is not included, but can be provided if required.
11. Elevated Paver Systems is a certified Woman Owned Business in the state of Oklahoma.

Pricing

Elevated Paver Systems will perform the above stated scope of work for a total sum of:
\$ 14,000.00 (Fourteen Thousand dollars)

Commencement of scope of work stated above is based on written approval of this Change Order Request. Please contact John Moss if you have any questions or concerns regarding this change.



Date 10/10/2016
John Moss - Project Manager
Elevated Paver Systems

Date
Robert Catcher
Magnum Construction, Inc.



Location of New Stone
Cladding Installation
(See the following
pages for details)

151703B - City Hall Renovations - Entry Plaza Planter Wall
COR 01 Drawing Mark Up - 10/10/2016

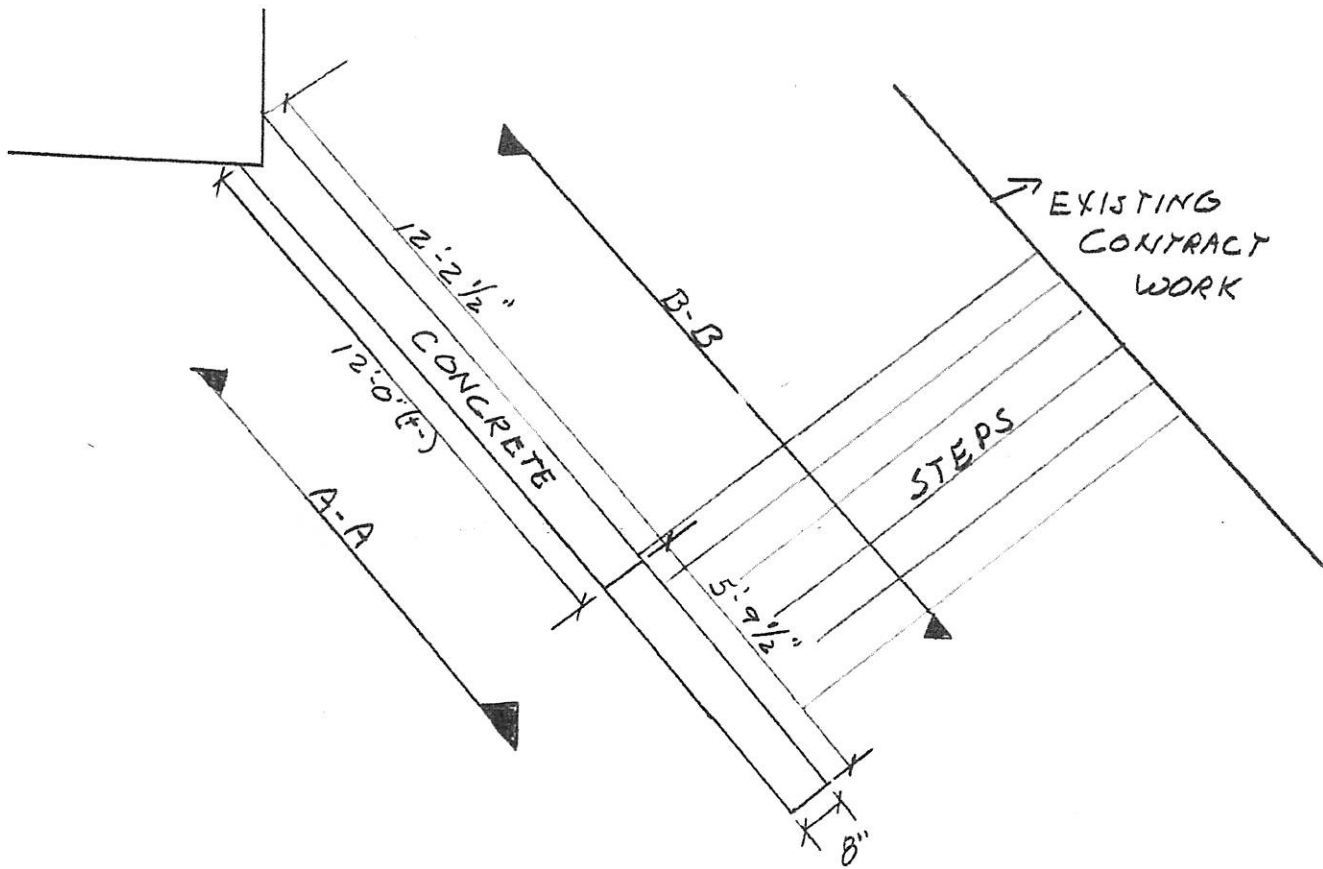

BA ENTRY - ADDED WALL

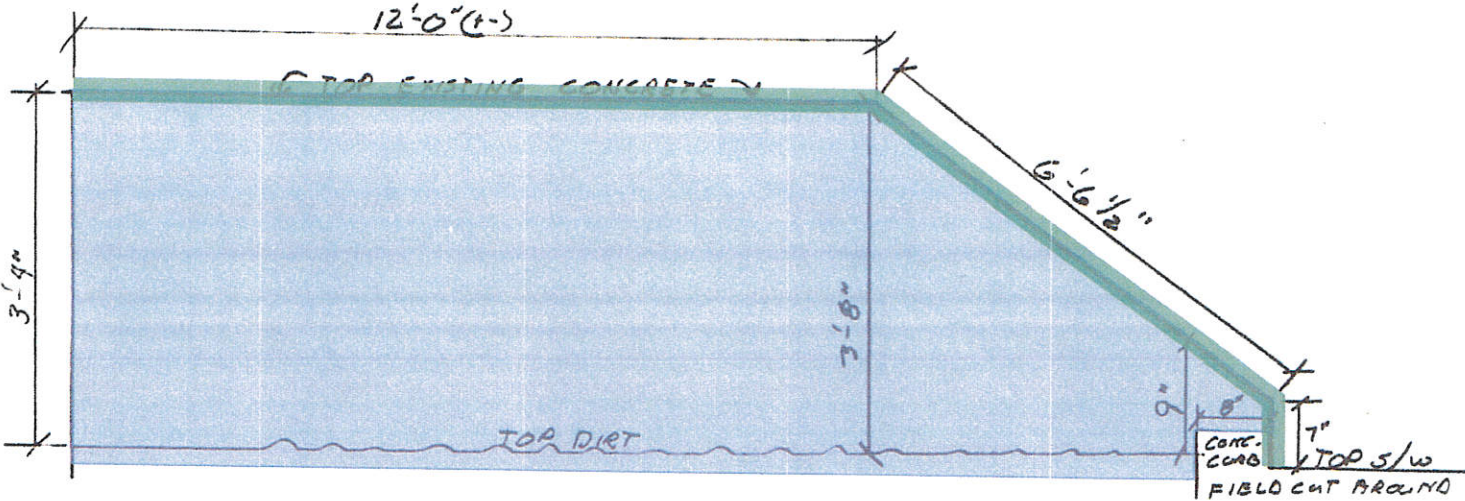

BA ENTRY - ADDED WALL



ELEVATION A-A

Material Legend	
	Stone Cap
	Stone Veneer

BA ENTRY - ADDED WALL

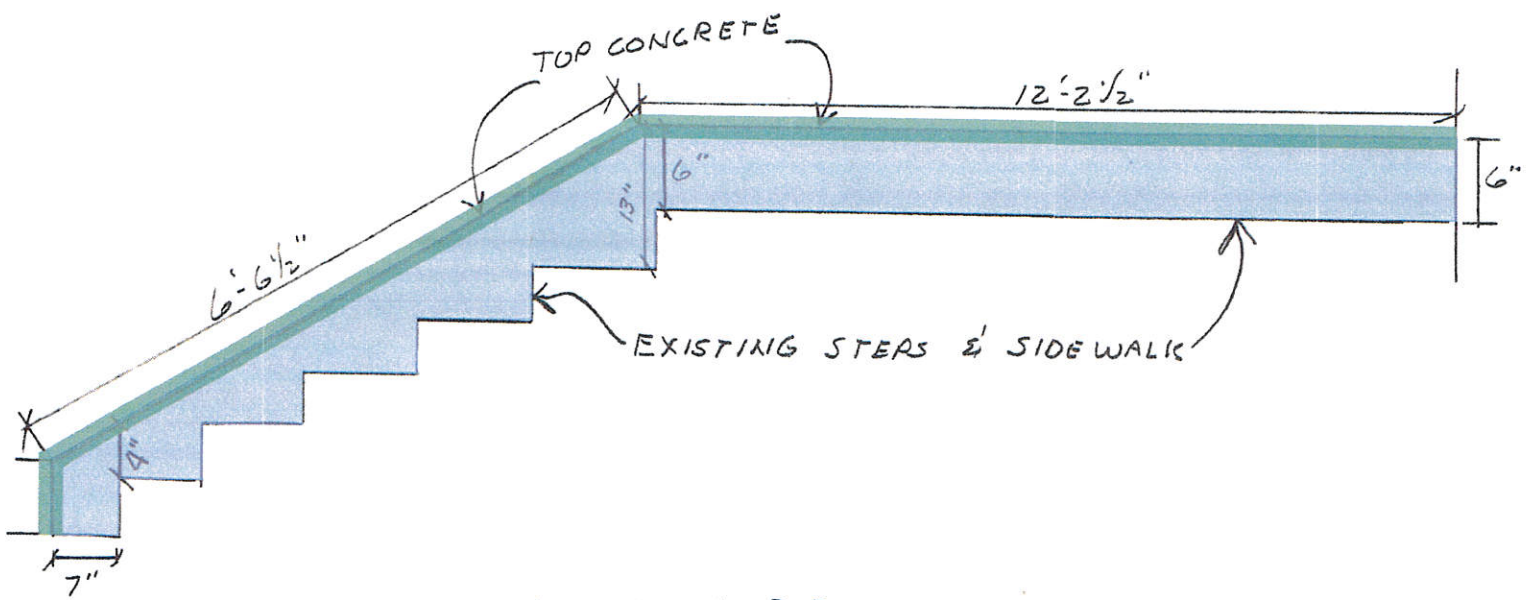

ELEVATION B-B

Material Legend

- Stone Cap
- Stone Veneer