



NOTE: ADDRESSES SHOWN ON THIS PLAT WERE ACCURATE AT THE TIME THIS PLAT WAS FILED. ADDRESSES ARE SUBJECT TO CHANGE AND SHOULD NEVER BE RELIED ON IN PLACE OF LEGAL DESCRIPTION.

BERWICK ON CEDAR RIDGE

6017 (BLOCKS 2, 3, 4, 5, & 6)

A REPLAT OF A PART OF CEDAR RIDGE CLUB ADDITION (PLAT NO. 2895) TO THE CITY OF BROKEN ARROW IN SECTION 30, T18N, R14E, I.B. & M., TULSA COUNTY, STATE OF OKLAHOMA



STATE OF OKLAHOMA }
 COUNTY OF TULSA } SS

I, Earlene Wilson, Tulsa County Clerk, in and for the County and State above named, do hereby certify that the foregoing is a true and correct copy of a like instrument now on file in my office.

Dated the 14 day of July 2006
 EARLENE WILSON, Tulsa County Clerk
 Kathy Whitford
 Deputy

OWNER/DEVELOPER:

RLAND DEVELOPMENT GROUP L.L.C.
 4765 E. 91st ST. STE 200
 TULSA, OKLAHOMA 74137 - PH# (918) 582-4300

REGISTERED LAND SURVEYOR:

COOK & ASSOCIATES ENGINEERING, INC.
 121 EAST COLLEGE STREET
 BROKEN ARROW, OKLAHOMA 74012 - PHONE: (918) 258-9442
 C.A. NO. 4479 EXPIRES 6/30/08

REGISTERED PROFESSIONAL ENGINEER:

JEREMY P. STAHL, PE# 21725
 CGA ENGINEERS, INC.
 8179 E. 41st STREET
 TULSA, OKLAHOMA 74145 - PH# (918) 749-5800
 C.A. No. 1371 EXPIRES 6/30/08

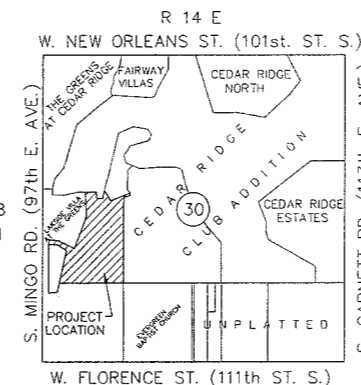

VICINITY MAP

LEGEND

BUILDING LINE	B/L
UTILITY EASEMENT	U/E
DETENTION EASEMENT	D/E
WATER LINE EASEMENT	WL/E
SIDEWALK EASEMENT	SW/E
FIRE HYDRANT EASEMENT	FH/E
RIGHT OF WAY	R/W
LIMITS OF NO ACCESS	L.N.A.
ACCESS	ACC
CURVE NO.	C1
PROPERTY LINE	
TRAFFIC CONTROL MEDIAN (TCM)	
FIELD MEASUREMENTS	S90°00'00"E
FINISH FLOOR	F.F.
STREET ADDRESS	6017
POWER POLES	PP

EXISTING ZONING:

- R-1 ONLY BLOCK 6, LOTS 8, 9, 10
- R-2 ALL OTHER LOTS

MONUMENTATION

IRON PINS SET AT ALL PROPERTY CORNERS

SUBDIVISION STATISTICS

SUBDIVISION CONTAINS 50 LOTS IN BLOCKS 2, 3, 4, 5, & 6
 SUBDIVISION CONTAINS 28.55 ACRES

IF THE ACTUAL FINISH FLOOR ELEVATION IS LESS THAN ONE (1) FOOT ABOVE THE TOP OF RIM ELEVATION OF THE UPSTREAM MANHOLE, IT SHALL BE THE BUILDERS RESPONSIBILITY TO INSTALL A BACKFLOW PREVENTER VALVE NEAR THE BUILDING ACCORDING TO THE BROKEN ARROW ORDINANCE NO. 1777, SECTION 24-100, ADOPTED MAY 17, 1993.

NOTES:

SOURCE OF WATER SUPPLY AND SEWAGE DISPOSAL IS THE CITY OF BROKEN ARROW.

NO BACK FLOW PREVENTER VALVES NEEDED.

- The basis of bearings (S00°00'00"W) is the previous platted bearing of the West boundary.
- Vertical Bench Mark: Top of 1/2" Iron Pin - the Southwest Section Corner of Section 30, T-18-N, R-14-E (111th & Mingo) Elev. 652.12 NGVD 1988.

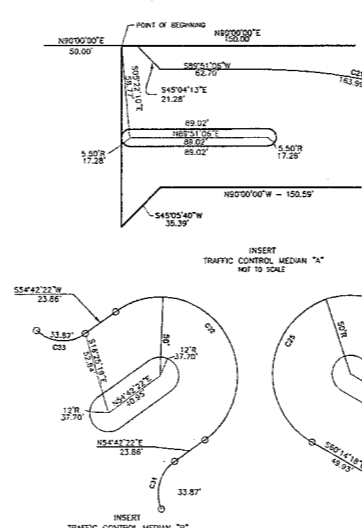

Stormwater detention accommodations for this site are provided by the onsite detention facility as shown in the "no exceptions taken" engineering plans in accordance with Fee-In-Lieu Of Detention Determination # DD-100603-65.



APPROVED 5-2-05 by the City Council of the City of Broken Arrow, Oklahoma.
 Richard Carter 7-13-06
 Mayor
 Attest: City Clerk 7.13.06

STATE OF OKLAHOMA }
 COUNTY OF TULSA } SS

I, Earlene Wilson, Tulsa County Clerk, in and for the County and State above named, do hereby certify that the foregoing is a true and correct copy of a like instrument now on file in my office.

Dated the ____ day of _____, 20__
 EARLENE WILSON, Tulsa County Clerk

CERTIFICATE

I hereby certify that all real estate taxes involved in this plat have been paid as reflected by the current tax rolls. Security as required has been provided in the amount of \$ 2,899.00 per trust receipt no. 7892 to be applied to 20__ taxes. This certificate is NOT to be construed as payment of 20__ taxes in full but is given in order that this plat may be filed on record. 20__ taxes may exceed the amount of the security deposit.

I hereby been paid a has been per trust n This ce taxes in full 20__ tax

Dated 14 July 2006
 Dennis S. ...
 Tulsa County Clerk
 Deputy

Berwick on Cedar Ridge

Blocks 2, 3, 4, 5, & 6

A Replat of a Part of Cedar Ridge Club Addition (Plat No. 2895) to the City of Broken Arrow in Section 30, Township 18 North, Range 14 East of the Indian Base and Meridian, Tulsa County, State of Oklahoma

DEED OF DEDICATION AND RESTRICTIVE COVENANTS KNOW ALL MEN BY THESE PRESENTS:

RLAND DEVELOPMENT GROUP, L.L.C., an Oklahoma limited liability company, hereinafter referred to as the "Owner", is the owner of the following described land in the City of Broken Arrow, Tulsa County, State of Oklahoma, to-wit:

A parcel of land located in part of Block One (1) CEDAR RIDGE CLUB ADDITION, an Addition to the City of Broken Arrow in Section 30, Township Eighteen North (T18N), Range Fourteen East (R14E), of the Indian Base and Meridian, Tulsa County, State of Oklahoma, according to the recorded plat there of, more particularly described as follows:

Commencing at the Northwest corner of said Section 30; thence S00°00'00"W along the West line of said Section 30 a distance of 3,239.08 feet; thence N90°00'00"E a distance of 50.00 feet to a point on the East right-of-way line of South Mingo Road also being the Southwest corner of the platted "Lakeside Villas at the Greens", said point being the Point of Beginning; thence N90°00'00"E along the South line of said "Lakeside Villas at the Greens" a distance of 150.00 feet; thence S65°00'25"E along the South line of said "Lakeside Villas at the Greens" a distance of 321.20 feet; thence N20°50'24"E along the East side of said "Lakeside Villas at the Greens" a distance of 597.43 feet; thence N04°08'34"W along the East side of said "Lakeside Villas at the Greens" a distance of 397.37 feet; thence N87°51'01"E a distance of 195.76 feet; thence S01°54'53"E a distance of 103.10 feet; thence S81°14'01"E a distance of 33.15 feet; thence S87°53'16"E a distance of 75.01 feet; thence N13°21'49"E a distance of 99.09 feet; thence S53°06'17"E a distance of 196.82 feet; thence along a curve to the right with a chord bearing of N66°54'29"E, a chord length of 38.05 feet, a radius of 500 feet for a distance of 38.06 feet; thence N69°05'19"E a distance of 293.24 feet; thence along a curve to the left with a chord bearing of N66°43'45"E, a chord length of 43.22 feet, a radius of 525 feet for a distance of 43.24 feet; thence S25°37'48"E a distance of 50.00 feet; thence along a curve to the right with a chord bearing of S66°43'45"W, a chord length of 47.34 feet, a radius of 575.00 feet for a distance of 47.35 feet; thence S69°05'19"W a distance of 149.47 feet; thence S00°42'20"W a distance of 448.78 feet; thence S00°08'37"E a distance of 991.86 feet to a point on the South line of the North half of the South half of Section 30; thence S89°52'55"W along the South line of the North half of the South half of Section 30 a distance of 1018.71 feet; thence N12°33'02"E a distance of 565.75 feet; thence N65°57'35"W a distance of 11.52 feet; thence N64°56'39"W a distance of 157.31 feet; thence along a curve to the left with a chord bearing of N77°28'20"W, a chord length of 73.36 feet, a radius of 169.10 feet for a distance of 73.95 feet; thence N90°00'00"W a distance of 150.68 feet; thence S45°05'40"W a distance of 35.39 feet to a point on the East right-of-way line of South Mingo Road; thence N00°00'00"E along the East right-of-way line of South Mingo Road a distance of 115.00 feet to the Point of Beginning. Said parcel containing 28.55 acres more or less.

and has caused the above described land to be surveyed, staked, platted and subdivided into Fifty (50) Lots, Five (5) Blocks and Four (4) Reserve Areas, in conformity with the accompanying plat and has designated the subdivision as "BERWICK ON CEDAR RIDGE, BLOCKS 2, 3, 4, 5 & 6", a Subdivision in the City of Broken Arrow, Tulsa County, State of Oklahoma (hereinafter sometimes referred to the "Subdivision"). Now, therefore, the Owner, for the purpose of providing for the orderly development of the Subdivision and for the purpose of insuring adequate restrictions for the mutual benefit of the Owner, its successors, grantees and assigns, and the beneficiaries of the covenants set forth in Section 1 below, with respect to such covenants only, does hereby impose the following restrictions and covenants, which shall be covenants running with the land and which shall be enforceable by the Owner or owners of any property within the Subdivision and by the beneficiaries of the covenants set forth in Section 1 below, with respect to such covenants only.

SECTION I. STREETS, EASEMENTS AND UTILITIES.

A. Public Street and General Utility Easements.

The Owner does hereby dedicate for public use the streets designated on the Plat and does hereby further dedicate for public use the utility easements shown and designated on the Plat as U/E for the several purposes of constructing, maintaining, repairing, removing and replacing any and all public utilities, including storm sewers, sanitary sewers, telephone and communication lines, cable television lines, electric power lines and transformers, gas lines and water lines, together with all fittings and equipment for each of such facilities including the poles, wires, conduits, pipes, valves, meters, and any other appurtenances thereto, with right of ingress and egress to such easements for the uses and purposes aforesaid; provided, however, the owner hereby reserves the right to construct, maintain, operate, lay and relay water and sewer lines, together with the right of ingress and egress over, across, and along all of the easement areas shown on the plat, for the purposes of furnishing water and/or sewer service to the area included within the Plat. The Owner hereby imposes a restrictive covenant, which covenant shall be binding on each lot owner and shall be enforceable by the City of Broken Arrow, Oklahoma, and by the supplier of any affected utility service, that within the utility easements depicted on the Plat, no building, structure or other above or below-ground construction that interferes with the above set forth uses and purposes of an easement shall be placed, erected, installed or maintained; provided however, nothing herein shall be deemed to prohibit drives, parking areas, curbing, landscaping, signs, and customary screening fences and walls.

Owner shall cause to be constructed sidewalks in the rights of way of the public streets in those areas where a Reserve Area abuts a public street.

B. Traffic Control Medians A, B, and C.

The Owner does hereby dedicate for Public Use Traffic Control Medians A, B, and C, provided however, the Owner herein reserves a perpetual easement to be subsequently conveyed to the homeowners association formed or to be formed as set forth within Section III hereof, for the purposes of installation and maintenance of landscaping, utilities and signage with Traffic Control Medians A, B, and C. The holder of the reserved easement, the Owner or the homeowners association as the case may be, herein covenants that the holder shall maintain any landscaping located within Traffic Control Medians A, B, and C and the City of Broken Arrow shall have no liability for any damage to landscaping, including irrigation systems, occasioned by maintenance or reconstruction of the Traffic Control Medians or maintenance or reconstruction of the adjoining public street.

C. Underground Service.

- Street light poles and standards shall be served by underground cable. All supply lines in the Subdivision, including electric, telephone, cable television and gas lines shall be located underground, in the easement-ways dedicated for general utility services and in the public streets as depicted on the Plat. Service pedestals and transformers, as sources of supply at secondary voltages, may also be located in said easement-ways; providing, however, that no service pedestals or transformers for electric, telephone, cable television or meters or pedestals for other utility services shall be located on the fronts of the lots.
- Underground service cables and gas service lines to all structures which may be located within the Subdivision may be run from the nearest gas main, service pedestal or transformer to the point of usage determined by the location and construction of such structure as may be located upon each lot; provided that, upon installation of a service cable or gas service line to a particular structure, the supplier of said service shall thereafter be deemed to have a definitive, permanent, effective and non-exclusive right-of-way easement on the lot, covering a five foot strip extending 2.5 feet on each side of the service cable or line extending from the gas main, service pedestal or transformer to the service entrance on said structure.
- The suppliers of electric, telephone, cable television and gas services, through their proper agents and employees, shall at all times have the right of access to all easement ways shown on the Plat or otherwise provided for in this Deed of Dedication for the purpose of installing, maintaining, removing, or replacing any portion of said underground electric, telephone, cable television or gas facilities installed by the supplier of the utility service.

4. The owner of the lot shall be responsible for the protection of the underground service facilities located on his lot and shall prevent the alteration of grade or any construction activity which would interfere with the electric, telephone, cable television or gas facilities. Each supplier of service shall be responsible for ordinary maintenance of underground facilities, but the owner shall pay for damages or relocation of such facilities caused or necessitated by acts of the owner or his agents or contractors. Said alterations of grade and limitation of construction activities shall be limited to easements and does not apply to areas outside of the easements designated on the Plat.

5. The foregoing covenants set forth in this Section C concerning underground electric, telephone, cable television and gas services shall be enforceable by each supplier of the electric, telephone, cable television or gas service and the owner of the lot agrees to be bound hereby.

D. Water and Sewer Services.

- Each owner shall be responsible for the protection of the public water mains, the public sanitary sewer main and storm sewers located on such lot.
- Within the utility easements depicted on the Plat, the alteration of grade elevations in excess of three (3) feet from the contours existing upon completion of the installation of a public water main or sewer main, or any construction activity which would interfere with the public water and sewer mains shall be prohibited.
- The City of Broken Arrow, Oklahoma, or its successors, shall be responsible for the ordinary maintenance of the public water and sewer mains, but the owner of each lot shall pay for damage or relocation of such facilities caused or necessitated by the act of such owner, his agents or contractors.

4. The City of Broken Arrow, Oklahoma, or its successors shall at all times have right of access to all easements depicted on the Plat, or otherwise provided for in this Deed of Dedication, for the purpose of installing, maintaining, removing or replacing any portion of underground water, sanitary sewer or storm sewer facilities.

5. The foregoing covenants set forth in this Section D shall be enforceable by the City of Broken Arrow, Oklahoma, or its successors, and the above Owner and the owner of each lot agrees to be bound hereby.

E. Gas Service.

- The supplier of gas service through its agents and employees shall at all time have the right of access to all such easements shown on the Plat or as provided for in this Deed of Dedication for the purpose of installing, removing, repairing, or replacing any portion of the facilities installed by the supplier of gas service.
- The owner of the lot shall be responsible for the protection of the underground gas facilities located in such owner's lot and shall prevent the alteration of grade, or any other construction activity which would interfere with the gas service. The supplier of the gas service shall be responsible for the ordinary maintenance of said facilities, but the owner shall pay for damage or relocation of such facilities caused or necessitated by the act of the owner, or the owner's agents or contractors.
- The foregoing covenants set forth in this Section E shall be enforceable by the supplier of the gas service and the owner of the lot agrees to be bound hereby.

F. Surface Drainage.

Each lot shall receive and drain, in an unobstructed manner, the storm and surface waters from lots and drainage areas of higher elevation and from public streets and easements. No lot owner shall construct or permit to be constructed any fencing or other obstructions which would impair the drainage of storm and surface waters over and across such owner's lot. The foregoing covenants set forth in this Section F shall be enforceable by any affected lot owner and by the City of Broken Arrow, Oklahoma.



APPROVED 5-2-06 by the City Council of the City of Broken Arrow, Oklahoma.
Richard Carter 7-13-06
Attest: City Clerk
7-13-06

Berwick on Cedar Ridge

Blocks 2, 3, 4, 5, & 6

A Replat of a Part of Cedar Ridge Club Addition (Plat No. 2895)
to the City of Broken Arrow in Section 30, Township 18 North, Range 14 East
of the Indian Base and Meridian, Tulsa County, State of Oklahoma

G. Paving and Landscaping within Easements.

The owner of the lot affected shall be responsible for repair of damage to the landscaping and paving occasioned by the necessary installation of or maintenance to the underground water, sewer, storm water, gas, communication, cable television or electric facilities within the easements depicted on the accompanying Plat, provided, however, that the City of Broken Arrow, or the supplier of the utility service shall use reasonable care in the performance of such activities.

H. Limits of No Access.

- The Owner hereby relinquishes right of ingress and egress to the above described property within the bounds designated as "Limits of No Access" ("L. N. A."), except as may hereafter be released, altered, or amended by the Owner and the Broken Arrow Planning Commission, or its successors, or as otherwise provided by the statutes and laws of the State of Oklahoma, pertaining thereto.
- The foregoing covenants concerning "Limits of No Access" ("L. N. A.") shall be enforceable by the City of Broken Arrow or its successors, and the owner of each lot agrees to be bound hereby.

I. Stormwater Detention and Drainage Areas.

The Owner does hereby dedicate to the City of Broken Arrow, Oklahoma, for public use (subject to easements of record) a perpetual easement on, over and across the property designated and shown on the accompanying plat as "D/E or Detention Easement", which are located in reserve areas "A", "B", "C" and "D", as shown on the accompanying plat for the several purposes of permitting the flow, conveyance, retention, detention and discharge of stormwater run-off from and through the Subdivision.

Detention, retention and other drainage facilities constructed within said easements shall be in accordance with standards and specifications approved by the City of Broken Arrow, Oklahoma (hereinafter referred to as the "City").

No fence, wall, building or other obstruction may be placed or maintained in the Detention Easements Area nor shall there be any alteration of the grades or contours in such easement area unless approved by the City.

Detention, retention and other drainage facilities shall be maintained by the Berwick on Cedar Ridge Homeowners Association, Inc., (the "Association") which shall be the owner of said Reserve Areas "A", "B", "C" and "D", to the extent necessary to achieve the intended drainage, retention and detention functions, including repair of appurtenances and removal of obstructions and siltation. Said detention facilities shall be maintained by the Association in accordance with the following standards:

- Grass areas shall be mowed (in season) at regular intervals of less than four (4) weeks minimum or as needed to maintain quality standards should weather conditions cause a faster growth pattern.
- Concrete appurtenances shall be maintained in good condition and replaced if damaged.
- Areas within the easements shall be kept free of debris.
- Cleaning of siltation and vegetation from concrete channels shall be performed twice yearly.

Notwithstanding any provision herein to the contrary, as to that portion of Reserve B which abuts Lots One (1) through Eight (8) of Block Six (6), the owners of each such lot, at said lot owner's expense, shall be responsible for maintenance items 1 and 3 above for that area between the property line of said lot and the water line of the existing pond. The owner may install landscaping in said area upon submission to and approval of plans therefor by the Architectural Committee (as hereinafter defined) and subject to the approval of the City. The owner of each lot shall be responsible for repair of any damage to said landscaping arising out of the maintenance or repair of the Detention Easement by the City or the Association.

In the event said lot owner fails to fulfill the foregoing obligations, the Association may do so and the owner of said lot shall reimburse the Association for the costs thereof and failure to do so may result in the imposition of a lien on said lot by the Association.

Landscaping approved by the City shall be allowed within the detention easements.

In the event said Association should fail to properly maintain said detention, retention and other drainage facilities or, in the event of the placement of an obstruction within, or the alteration of the grades or contours therein without the approval of the City, the City or its designated contractor may enter said area and perform the maintenance necessary to achieve the intended drainage functions and may remove any obstruction or correct any alteration of grade or contour, and the cost thereof shall be paid by said Association. In the event said Association fails to pay the cost of maintenance thereof within (30) days after completion of the maintenance and receipt of a statement of costs, the City may file a record copy of the statement of costs, and thereafter the costs shall be a lien against each lot within the Subdivision. A lien established as above provided may be foreclosed by the City.

SECTION II. BUILDING AND USE RESTRICTIVE COVENANTS.

For the purpose of providing an orderly development of the Subdivision, to protect the desirability of the Subdivision and the values thereof, and for maintaining conformity of the improvements therein, the following restrictions and covenants are hereby imposed upon the use and occupancy of the lots within the Subdivision, which shall be covenants running with the land and shall be binding upon the Owner, its successors and assigns and shall be enforceable as hereinafter provided.

A. Architectural Committee - Plan Review.

1. Formation.

Owner hereby forms an architectural committee (the "Architectural Committee") that shall:

- approve all plans for any structure to be built on any lot and any modifications or alterations thereto; and
- be responsible for interpreting the development and construction standards contained herein and in any building guidelines developed by the Architectural Committee.

2. Membership.

The Architectural Committee shall consist of not less than one (1) nor more than five (5) members to be appointed by Owner until Owner, in its sole discretion, assigns and transfers the responsibility for the appointment of the Architectural Committee to the Association to be formed pursuant to Section III below.

3. Submission of Plans.

No building, fence, wall, free standing mailbox or any other improvements or structure may be commenced, erected, constructed or placed on any lot in the Subdivision without the written approval of the Architectural Committee. The architectural plans to be submitted and approved in accordance herewith shall be submitted in duplicate and shall include, at a minimum, the following with regard to each improvement to be constructed on any lot in the Subdivision, which must be approved prior to submittal to the City.

- An accurate site plan;
- An accurate floor plan;
- All exterior elevations;
- A hardscape plan, including the composition, location and height of fencing and hardscape materials;
- Any other plans or information requiring the approval of the City or the Broken Arrow Planning Commission pursuant to Section II of this Deed of Dedication;
- Details regarding the composition of all roofing and external building materials, including color schemes;
- Drainage and grading plans; and
- Any other plans or details required by the Architectural Committee.

In passing upon such plans, specifications, plot plans, drainage and grading plans, the Architectural Committee may take into consideration the suitability of the proposed building or other structures and of the material of which it is to be built to the site upon which it is proposed to erect the same, the harmony thereof with the surrounding buildings and lots and the effect of the building or other structures as planned on the view from the adjacent or neighboring lots.

B. Residential Lots Use.

All lots in the Subdivision (excepting Reserve Areas) shall be known and described as residential lots and shall be limited to use for detached single-family residences and purposes only. No trade or business shall be permitted on any lot.

C. Reserve Areas Use.

Reserve Areas designated on the accompanying Plat shall be used only for open space, passive recreational uses, storm water detention and drainage, landscaping and where specifically designated, for utility easements. All reserve areas shall be owned by and maintained, except as otherwise provided herein by the Association as provided in the Declaration of Covenants, Conditions and Restrictions of Berwick on Cedar Ridge (the "Declaration") and the rules and regulations of the Association.

D. Fronting and Access Limitation.

Each dwelling shall face the street and derive its access solely from the public street.

E. Yards and Setbacks.

1. Minimum Building Setback from Public Street Right-of-Way.

No building shall be constructed nearer to the right-of-way of the public street right-of-way than 25 feet.

2. Minimum Side Yards.

Both: 15 feet
One Side Yard: 10 feet
Other Side Yard: 5 feet

3. Minimum Rear Yard.

The minimum rear yard shall be 20% of the depth of the Lot.

4. Minimum Lot Area and Lot Boundary Adjustment.

No lot shall be lot-split or re-subdivided into a parcel having an area of less than 8,000 square feet of land area, unless the resulting parcel is held in common ownership with an adjoining parcel and the resulting area of common ownership is not less than 8,000 square feet. Whereby reason of lot-splitting or by reason of common acquisition of an adjoining lot, a lot line as originally platted divides the ownership, the owner may declare by recorded document that his ownership line shall serve as lot lines, and thereafter all yards and setbacks shall be measured from the declared lot lines, and the ownership lines shall be deemed to establish a single lot for the purposes of determining permitted principal and accessory uses. It is the intent of the foregoing provisions to permit adjustment in lot boundaries, but in no event shall an ownership area be less than 8,000 square feet, nor shall the number of dwelling units within the Subdivision exceed 50.

5. Minimum Lot Width and Lot Frontage.

The minimum lot width shall be 70 feet measured at the building line. However, all lots shall have at least 40 feet of frontage along the street right-of-way.

F. Maximum Structure Height.

No structure may be constructed or erected on any lot in excess of 35 feet in height and two stories.

G. Floor Area.

Single story dwellings shall have a minimum of 2,700 square feet of living area. Multi-story dwellings shall have a minimum of 3,100 square feet of living area; provided, however, that the first floor shall have a minimum of 2,250 square feet of living area. The computation of square feet of living area shall exclude garages, open spaces and breeze ways.

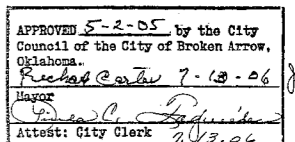

Berwick on Cedar Ridge

Blocks 2, 3, 4, 5, & 6

A Replat of a Part of Cedar Ridge Club Addition (Plat No. 2895)
to the City of Broken Arrow in Section 30, Township 18 North, Range 14 East
of the Indian Base and Meridian, Tulsa County, State of Oklahoma

H. Foundations.

All exposed foundations shall be of brick, stucco or stone. No concrete blocks, poured concrete or any other foundation will be exposed. No stem walls shall be exposed.

I. Garages and Driveways.

An attached garage providing spaces for a minimum of two (2) automobiles shall be provided on each lot. Garages shall be enclosed and no windows shall be permitted in the garage doors. Carports are prohibited. All driveways shall be concrete or other masonry approved by the Architectural Committee.

J. Masonry.

- For lots zoned R-1, one hundred percent (100%) of the surface of exterior walls (excluding windows and doors) shall be brick, stone or stucco except under covered porches and patios.
- For lots zoned R-2, one hundred percent (100%) of the surface of exterior walls (excluding windows and doors) shall be brick, stone or stucco except under covered porches and patios, provided that the exterior walls above the first floor elevation wall may be constructed of wood, masonite or a comparable siding product.

K. Windows and Doors.

All windows frames and doors shall be either wood, vinyl clad wood or vinyl. Aluminum windows having a mill finish are prohibited.

L. Roof Pitch.

No dwelling shall have a roof pitch of less than 9/12; providing, however, that a roof over a porch shall have a roof pitch of no less than 6/12 if gable or 4/12 if shed. All front gables shall have no less than a 12/12 pitch and all rear gables on Lots 1-7, 12-14 and 16-17, Block 5 and Lots 1-10, Block 6 shall also have no less than a 12/12 pitch.

M. Roofing Materials.

Roofing shall be self-sealing Tamko Heritage 30 year, oxford gray composition shingles or equivalent; providing, however, in the event such roofing should hereinafter not be reasonably available, alternative roofing of comparable quality shall be permitted upon a determination of the Architectural Committee that the proposed alternative is of comparable or better quality and of a design and quality which is compatible with the roofing first described.

N. Antennas.

Exterior antennas or other devices (including supporting structures) for the transmission or reception of radio, television, satellite signals or other forms of electro-magnetic radiation are prohibited, except that within each lot one satellite dish, not exceeding eighteen inches (18") in diameter, is permitted. The location of any such satellite dish must be approved by the Architectural Committee and shall be, whenever possible, such that the satellite dish is not visible from any public or private street or from the Cedar Ridge Country Club golf course.

O. Materials and Storage.

No lot will be used for the storage of materials for a period of greater than thirty (30) calendar days prior to the start of construction, and then the construction shall be completed within six (6) months. All lots shall be maintained in a neat and orderly condition at all times.

P. Recreational Vehicles.

No campers, boats, trailers, motor homes or other recreational vehicles shall be parked or stored in the Subdivision for a period to exceed seventy-two (72) hours except within an enclosed garage, which garage door must be closed except for normal operation for entering and exiting the garage.

Q. Inoperative Vehicles.

No inoperative vehicle or machinery shall be stored on any lot, except within an enclosed garage, which garage door must be closed except for normal operation for entering and exiting the garage.

R. Maintenance of Lots.

Each lot shall be maintained in a neat and orderly manner free of clutter, rubbish, trash or other debris and shall be cut, trimmed or mowed to prevent growth of weeds or tall grass. Grass and landscaping shall be maintained on a regular basis. Trash containers, except during periods of collection, shall be stored out of view from the public and from adjoining property owners. No exposed garbage cans, trash can or any trash burning apparatus or structure shall be placed on any lot.

S. Surface Drainage.

The owner of each lot shall maintain the surface drainage, either natural or artificial, over and across such lot. No owner shall construct or permit any fencing or other obstruction which would impair the draining of storm water over and across the lot. No lot owner shall modify or change the direction of surface storm water from the original, approved drainage plan constructed on the lot.

T. On-Site Construction.

Each dwelling must be constructed on-site and no dwelling built off-site shall be placed on any lot.

U. Outbuildings.

Outdoor storage buildings are not permitted. Other outbuildings, such as gazebos or cabanas, shall be permitted subject to the approval of the location, style and materials used in the construction by the Architectural Committee prior to construction, and providing that the outbuilding is compatible in material and style with the primary residence. No outbuilding shall be erected in a location on the lot that the Architectural Committee determines would unreasonably obstruct the view of the golf course, a water feature or a greenbelt from another lot.

V. Swimming Pools.

Above ground swimming pools are prohibited. Any pool or spa shall be in-ground and permanent. Lots with swimming pools shall have sufficient security fencing as required by code. Swimming pool ancillary equipment shall be shielded from view from the street and adjacent lots.

W. Interior Fences.

Restrictions Applicable to All Lots.

All fences and walls must be approved by the Architectural Committee. Each owner of a lot shall be responsible for the maintenance of fencing on such lot. No fence shall extend beyond the front building line of any lot.

Except as provided hereinafter, all fences shall be constructed entirely of wood, brick, stone, wrought iron or another approved metal approved by the Architectural Committee having the appearance of wrought iron ("wrought iron-style") or some combination thereof. Vinyl, chain link, barbed wire, meshed or other metal fences are prohibited. No fence shall exceed six (6) feet in height.

Restrictions Applicable Only to Block 6.

No fence on any lot in Block 6 shall exceed four (4) feet in height. No fence or wall shall be allowed which, in the opinion of the Architectural Committee, unreasonably obstructs a golf course or water view from an adjoining lot.

Any fences located on Lots 8, 9 and 10, Block 6, of the Subdivision that are within thirty (30) feet of the Cedar Ridge Country Club property shall be of the identical type, style and height as the Cedar Ridge Country Club fence erected along the common property line of the lot and the Cedar Ridge Country Club. The owner of such lot may connect the fence to the Cedar Ridge Country Club's fence, all in accordance with the terms and conditions of the Fence Agreement by and between Cedar Ridge Country Club, Inc. and the Owner filed of record in the Office of the County Clerk of Tulsa County, Oklahoma.

Any fence located on or within the area lying thirty (30) feet east of the west property line of Lots 1 through 8 shall be four (4)-foot wrought iron-style fence conforming to specifications in the building guidelines of the Architectural Committee. Provided, however, that fencing located along the southwest property line of Lot 1, Block 6, and in that part of Reserve "B" lying southwest of Lot 1, Block 6, may be of a different style and height with the approval of the Architectural Committee.

Restrictions Applicable Only to Lots Abutting Reserve Area "D" (Lots 1-7, 12-14, 16 and 17, Block 5).

All lots abutting Reserve Area "D" shall have and the owners of such lots shall install along the property line abutting Reserve Area "D" a 5-foot high wrought iron-style fence conforming to specifications in the building guidelines of the Architectural Committee. This fence shall be completed prior to occupancy of a home on such lot. Any fence installed along the side lot lines of these lots and within twenty-five (25) feet of the rear lot line shall be of the identical wrought iron-style and height.

Restrictions Applicable Only to Lots Abutting Reserve Area "A" (Block 2, Lots 1, 2, 4, 5 and 6).

Any fence located on or within the area lying thirty (30) feet from the rear property line shall be four (4)-foot wrought iron-style fence conforming to specifications in the building guidelines of the Architectural Committee. No fence or wall shall be allowed which, in the opinion of the Architectural Committee, unreasonably obstructs a water view from an adjoining lot.

X. Clotheslines.

Exposed clothesline poles or other outside drying apparatus are prohibited.

Y. Mailboxes.

All mailboxes shall be constructed of materials, size, location and style approved by the Architectural Committee and shall be uniform for each neighborhood.

Z. Animals.

No animals, livestock or poultry of any kind may be maintained, bred, sold or kept on any lot, except that no more than two (2) dogs, two (2) cats or other customary and normal household pets may be kept, provided that they are not used for commercial purposes. All pets must be leashed, except in an enclosed fenced area and each owner shall be responsible for not permitting barking or other noise or activity by such pets which are a nuisance to adjoining lot owners. No exotic wild life shall be permitted.

AA. Noxious Activities.

No noxious, loud, annoying or offensive activity shall be carried out upon any lot nor shall anything be done thereon which that may be or may become an annoyance or nuisance to the neighborhood.

BB. Signage.

No sign of any kind shall be displayed to the public view on any lot, except one sign of not more than six (6) square feet in area advertising the property for sale; providing, however, nothing contained herein shall be construed to prohibit signs advertising the Subdivision and homes for sale by the Owner or its designated builders.

CC. Exterior Lighting, Alarms and Video.

No spotlights, flood lights or other high intensity lighting or alarms and video and audio equipment shall be placed upon or utilized upon any lot in a manner which unreasonably interferes with the enjoyment of adjoining lots.

DD. Chimneys.

All chimney caps shall be copper or clay. All chimneys shall be of masonry or masonry veneer construction, except that the side facing the roof may be constructed of wood, masonite or a comparable siding product.

EE. Guttering, Flashing and Roof Vents.

All dwellings shall be fully guttered with "tight-lines" to the street. All exposed exterior roof vents, flashing and valleys shall be either copper or aluminum painted to match the rooftop. All exterior venting shall be in the rear of the residence, if possible.



APPROVED 5-2-05 by the City
Council of the City of Broken Arrow,
Oklahoma.
Richard Carter 7-13-06
Attest: City Clerk 7-13-06

Berwick on Cedar Ridge

Blocks 2, 3, 4, 5, & 6

A Replat of a Part of Cedar Ridge Club Addition (Plat No. 2895) to the City of Broken Arrow in Section 30, Township 18 North, Range 14 East of the Indian Base and Meridian, Tulsa County, State of Oklahoma

FF. Landscaping.

Restrictions Applicable to All Lots.

A hardscape plan for each lot must be submitted to and approved by the Architectural Committee prior to the commencement of construction on any lot. No cottonwood, mimosa, mulberry or other aesthetically undesirable trees or plants shall be used in the landscaping of any lot. No trees under three inches in diameter shall be planted or maintained on a lot as part of the initial, approved landscaping. All yards shall be fully sprinkled with an underground, permanent system regulated by an interior control system. Any terracing must be accomplished with hardscape materials approved by the Architectural Committee. Railroad ties are prohibited.

Additional Restrictions of Blocks 2, 3, 4 and 5.

All lots must be completely sodded on the completion of a residence and prior to the occupancy thereof. The front of all homes in Blocks 2, 3, 4 and 5 must be landscaped upon completion and prior to occupancy of the home on each lot. The initial landscaping shall be at a cost of no less than \$2,000.00 for the front yard. A minimum of two trees will be planted in the front yard. The rear yards of all Lots abutting Reserve Area "D" shall also be landscaped on completion and prior to occupancy of the home at a cost of not less than \$1,000.00 and the rear yard landscaping shall include at least one tree.

Additional Restrictions of Block 6.

All lots must be completely sodded on the completion of a residence and prior to the occupancy thereof. The front and rear of all homes in Block 6 must be landscaped upon completion and prior to occupancy of the home on each lot. The initial landscaping shall be at a cost of no less than \$2,000.00 for the front yard and \$1,000.00 for the rear yard. A minimum of two trees will be planted in the front yard and one tree in the rear yard.

GG. Exterior Heating, Ventilation and Air Conditioning Equipment.

All exterior heating, ventilation and air conditioning equipment shall be screened from view. No window units shall be permitted.

HH. Utility Transformers.

All transformers and similar equipment located on a lot shall be screened from view.

SECTION III. HOMEOWNERS ASSOCIATIONS.

A. Berwick on Cedar Ridge Homeowners Association, Inc.

1. Formation.

The accompanying Plat of Berwick on Cedar Ridge, Blocks 2, 3, 4, 5 and 6, is a phase of a larger planned residential community which shall initially include the Subdivision, "Berwick on Cedar Ridge Block 7" and "Berwick on Cedar Ridge Block 1" (hereinafter all of the foregoing are collectively referred to as "Berwick on Cedar Ridge"). It is intended that the homeowners within each developed phase of Berwick on Cedar Ridge shall be included as members of a master homeowners association and in certain phases having distinct and separate common area interests, homeowners will also be members of a separate neighborhood association as more fully set forth in the Declaration. Accordingly, the Owner has formed or has, accord, cause to be formed, an association of the owners of all residential lots within Berwick on Cedar Ridge, which shall be named "Berwick on Cedar Ridge Homeowners Association, Inc. for the general purposes of maintaining the private streets, entryways, storm water management and detention areas, reserve areas, trees and other common areas, in order to enhance the desirability and attractiveness of Berwick on Cedar Ridge, which includes all lots in the accompanying Plat, the foregoing subdivisions and any properties annexed thereto.

2. Membership.

Every record owner of a fee interest of a lot in the Subdivision shall be a member of the Association and such membership shall be appurtenant to and may not be separated from ownership of a lot. The acceptance of a deed shall not constitute acceptance of membership in the Association.

3. Assessments.

Each record owner of the fee interest in a lot in the Subdivision covenants and agrees to pay to the Association an annual assessment established by the Association, which shall be no less than the minimum amount necessary to adequately maintain and support all common areas of interest, including, without limitation, all reserve areas as designated on the plat and within the Subdivision. The annual assessment on each lot shall be a lien on each lot as set forth in the Declaration and the Instrument of Formation for the Association filed in the Office of the County Clerk, Tulsa County, Oklahoma.

4. Maintenance.

The Association shall be responsible for the maintenance of the common areas, the common area improvements, private streets and landscaping within all reserve areas designated on the Plat and the reserve areas are reserved for subsequent conveyance by the Owner to the Association. These facilities shall be maintained by the Association as more fully set forth in the Declaration.

SECTION IV ENFORCEMENT, DURATION, AMENDMENT AND SEVERABILITY.

A. ENFORCEMENT.

The covenants and restrictions set forth herein shall be covenants running with the land and which shall be binding upon the Owner, its grantees, successors and assigns. In the event the Owner or any of its successors, grantees, lessees or assigns, or any person claiming under them, shall violate or breach any of the covenants and restrictions set forth herein or imposed hereby, the Owner or any other owner of a lot in the Subdivision, shall have the right to maintain an action at law or in equity against the person or persons attempting to violate any of such covenants or restrictions to prevent violation and to recover damages for the violation thereof. The prevailing party in any such suit shall be entitled to recover a reasonable attorney's fee and the costs of the action.

Within the provisions of Section I, Streets, Easements and Utilities, are set forth certain covenants and certain enforcement rights pertaining thereto and shall inure to the benefit of and shall be enforceable by the City in the event the Owner or any of its successors or assigns, or any person claiming under them shall violate or breach any of the covenants and restrictions set forth therein or imposed thereby. The beneficiaries of the covenants as set forth in Section I hereof with respect to such covenants only, shall have the right to maintain any action at law or in equity against the person or persons attempting to violate any of such covenants or restrictions to prevent violation or to recover damages for the violations thereof. In the event the Owner or any of its successors, grantees, lessees or assigns, or any person claiming under them, shall violate or breach any of the covenants and restrictions set forth herein or imposed hereby, the City shall have the right to maintain an action at law or in equity against the person or persons attempting to violate any of such covenants or restrictions to prevent violation or to recover damages for the violation thereof.

B. Duration.

These restrictions, to the extent permitted by applicable law, shall be perpetual but in any event shall be in force and effect for a term of not less than thirty (30) years from the date of the recording of this Deed of Dedication, unless sooner terminated or amended as hereinafter provided.

C. Severability.

Invalidation of any covenant or restriction set forth herein, or any part thereof by an order, judgment, or decree of any court, or otherwise, shall not invalidate or affect any of the other restrictions or any part thereof as set forth herein, which shall remain in full force and effect.

D. Amendment.

The covenants contained within Section I, Streets, Easements and Utilities herein may be amended or terminated at any time by a written instrument signed and acknowledged by the owner of the lot or parcel to which the amendment or termination is to be applicable and approved by the Broken Arrow City Council or its successors and the City. The covenants within Section II, Building and Use Restrictions and the covenants within Section III, Homeowners Association may be amended or terminated by a written instrument signed and acknowledged by the Owner during such time as it owns any lot in the Subdivision or any lot in any of the other phases of Berwick on Cedar Ridge without the approval of any other lot owners, or, in the alternative, by the owners of at least sixty-five percent (65 %) of the lots in the Subdivision; PROVIDING, HOWEVER, that so long as the Owner owns any lot in the Subdivision or any lot in any of the phases of Berwick on Cedar Ridge, any such amendment must be approved in writing by the Owner. The Owner may delegate its right to approve any such amendment to the Architectural Committee. Any such amendment shall be effective from and after the date it is properly executed and recorded in the Office of the County Clerk of Tulsa County, Oklahoma.

IN WITNESS WHEREOF, RLAND Development Group, L.L.C., has executed this instrument this 17th day of July, 2006.

RLAND Development Group, L.L.C.,
an Oklahoma limited liability company

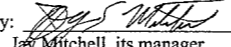
By: 
Jay Mitchell, its manager

CERTIFICATE OF SURVEY

I, BRIAN DAVID SCOTT, A Professional Land Surveyor in the State of Oklahoma, do hereby certify that I have carefully and accurately surveyed, subdivided, and platted the tract of land described above, and that the accompanying plat designated herein as 'Berwick on Cedar Ridge, BLOCKS 2, 3, 4, 5 and 6', a subdivision in the City of Tulsa, Tulsa County, State of Oklahoma, is a true representation of the survey made on the ground using generally accepted practices and meets or exceeds the Oklahoma Minimum Standards for the Practice of Land Surveying as of this date. signed and sealed this 17th Day of July 2006.

BRIAN DAVID SCOTT, PROFESSIONAL LAND SURVEYOR OKLAHOMA NO. 1585



State of Oklahoma)
)ss
County of Tulsa)

Before me, the undersigned, a notary public in and for said county and state, on this 17th day of July, 2006, personally appeared Jay Mitchell, to me known to be the identical person who subscribed the name of the maker thereof to the foregoing instrument as its manager and Brian David Scott, to me known to be the identical person who subscribed his name as registered professional land surveyor to the foregoing certificate as his free and voluntary act and deed for the uses and purposes therein set forth.
Given under my hand and seal the day and year last above written.

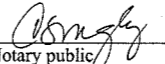
Notary public
11-16-08
My commission expires:



Number: 07017053

APPROVED 5-2-05 by the City Council of the City of Broken Arrow, Oklahoma.
Richard Carter 7-13-06
Mayor
James C. Fogel
Attest: City Clerk 7.13.06

