



EXHIBIT 'A'

5907 P.U.D. 161 Bricktown West Extended

A SUBDIVISION IN THE CITY OF BROKEN ARROW, TULSA COUNTY, OKLAHOMA BEING A REPLAT OF LOT ONE (1) BLOCK TWO (2), BRICKTOWN WEST (PLAT #5796) AND A SUBDIVISION OF A PART OF THE SOUTHWEST QUARTER OF THE SOUTHWEST QUARTER (SW/4 SW/4) OF SECTION FOUR (4), TOWNSHIP 18 NORTH, RANGE 14 EAST OF THE INDIAN BASE AND MERIDIAN.

Owner/Developer
 BRICKTOWN WEST, L.L.C.
 9708 EAST 55th PLACE
 TULSA, OKLAHOMA 74146
 (918) 663-6300
 MANAGER: MR. DARRELL G. JENKINS

Engineer/Surveyor
 HALL, ROSENBAUM, ALMON & ASSOCIATES, INC.
 1913 WEST TACOMA, SUITE-C
 BROKEN ARROW, OKLAHOMA 74012-1472
 PHONE: (918) 258-3737
 FAX: (918) 258-2554
 C.A.#3643 EXPIRES JUNE 30, 2007

PLAT No.
 []

STORMWATER DETENTION ACCOMMODATIONS FOR THIS SITE ARE PROVIDED BY THE ONSITE DETENTION FACILITY AS SHOWN IN THE "NO EXCEPTIONS TAKEN" ENGINEERING PLANS IN ACCORDANCE WITH FEE-IN-LIEU OF DETENTION DETERMINATION #DD-122903-76.

BLOCK	LOTS	FINISH FLOOR ELEVATION	UPSTREAM MANHOLE	TOP OF RIM ELEVATION
1	1	697.00	C	685.37
1	2	698.50	5	696.75
1	3	701.00	A	699.58
2	1	697.00	D	692.40
2	2	698.00	LH-a	695.95
2	3	700.00	2	696.14

IF THE ACTUAL FINISH FLOOR ELEVATION IS LOWER THAN ONE (1) FOOT ABOVE THE TOP OF RIM ELEVATION OF THE UPSTREAM MANHOLE, IT SHALL BE THE BUILDER'S RESPONSIBILITY TO INSTALL A BACKFLOW PREVENTER VALVE NEAR THE BUILDING ACCORDING TO BROKEN ARROW ORDINANCE NO. 1777, SECTION 24-100, ADOPTED MAY 17, 1993.
 * REQUIRES BACKFLOW PREVENTER VALVE.

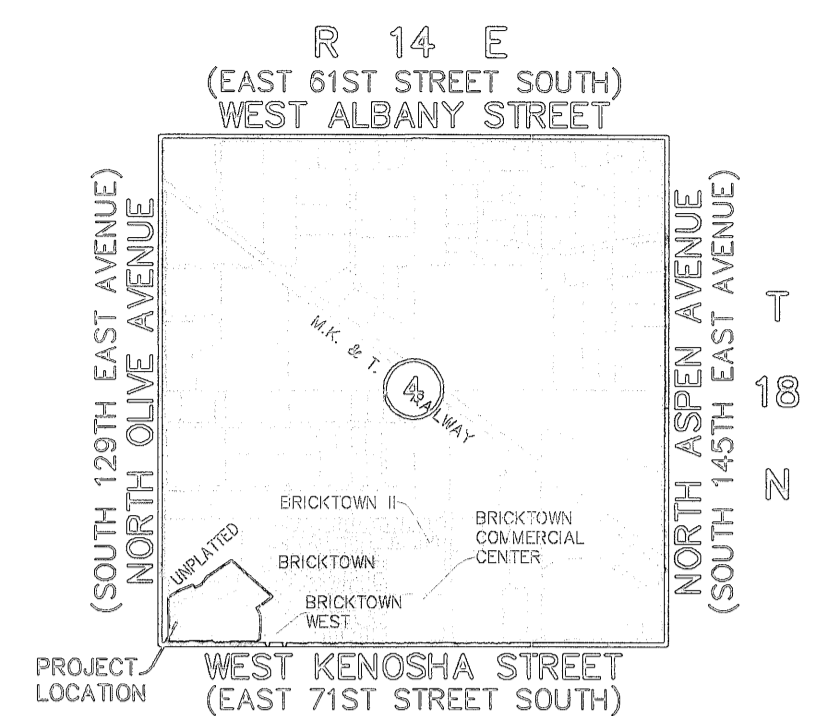

Location Map
 SCALE: 1"=200'
 Subdivision Contains Six (6) Lots in Two (2) Blocks
 Block 1 contains 3 lots
 Block 2 contains 3 lots
 630,835.83 SF / 14.48 Acres

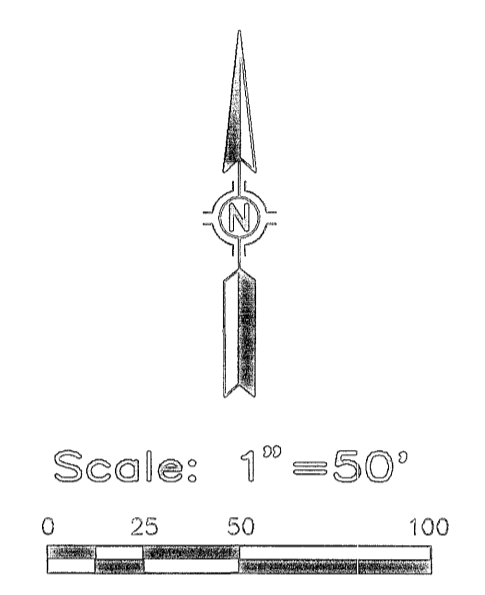

Basis of Bearing
 PLATTED BEARING OF S 89°23'04" W ALONG THE SOUTH LINE OF "BRICKTOWN WEST" AN ADDITION TO THE CITY OF BROKEN ARROW, TULSA COUNTY, STATE OF OKLAHOMA (PLAT NO. 5231)

Benchmark
 3/4" x 3/4" ALUMINUM CAP-FLUSH-SET IN CONCRETE POST-STAMPED "BA38", SET ON THE NORTH SIDE OF ALBANY AND EAST END OF EXPRESSWAY OVERPASS ELEVATION = 776.99 (NGVD 1929)

Notes
 ADDRESSES SHOWN ON THIS PLAT WERE ACCURATE AT THE TIME THIS PLAT WAS FILED. ADDRESSES ARE SUBJECT TO CHANGE AND SHOULD NEVER BE RELIED ON IN PLACE OF LEGAL DESCRIPTION.

ALL WATER AND SANITARY SEWER SERVICES WILL BE SUPPLIED AND MAINTAINED BY THE CITY OF BROKEN ARROW.

Monumentation
 ALL CORNERS SHOWN HEREON WERE SET USING A 3/8" x 18" STEEL PIN WITH A PLASTIC CAP STAMPED "PLS 1263" AT ALL CORNERS.

STATE OF OKLAHOMA }
 COUNTY OF TULSA }
 I, Earlene Wilson, Tulsa County Clerk, in and for the County and State above named, do hereby certify that the foregoing is a true and correct copy of a file instrument now on file in my office.
 Dated the 10th day of October, 2005
 EARLENE WILSON, Tulsa County Clerk
 Deputy

APPROVED 8-1-05 by the City Council of the City of Broken Arrow, Oklahoma.
 Richard Carlow
 Mayor
 Linda C. Aquino
 Attest: City Clerk 10-4-05



CERTIFICATE
 I hereby certify that all real estate taxes involved in this plat have been paid as reflected by the current tax rolls. Security as required has been provided in the amount of \$ 3,747.00 per trust receipt no. 6921 to be applied to 20 05 taxes. This certificate is NOT to be construed as payment of 20 taxes in full but is given in order that this plat may be filed on record. 20 taxes in full the amount of the security deposit.
 Dated 04-Oct-05
 Dennis Semler
 Tulsa County Treasurer
 Deputy

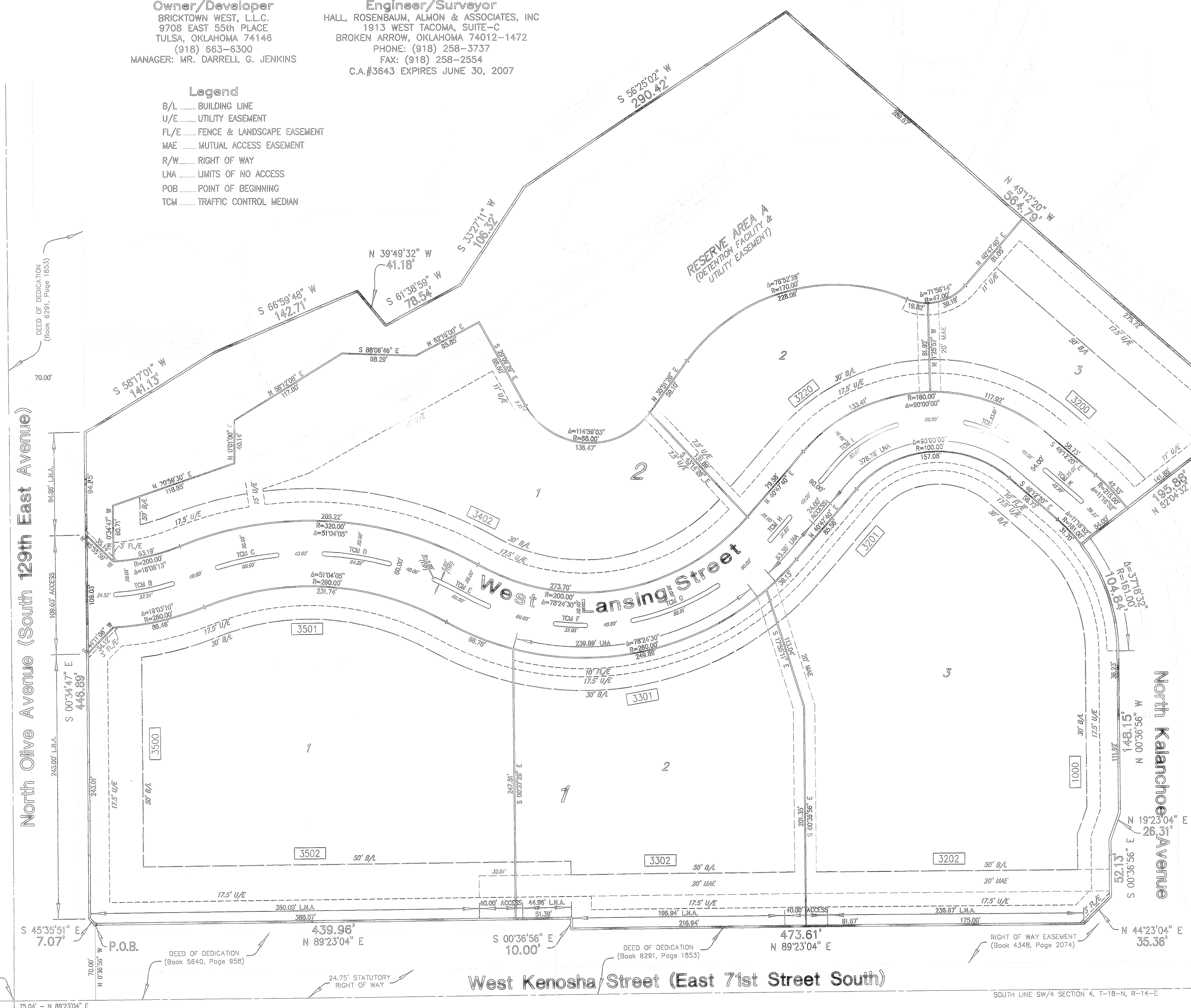

POINT OF COMMENCEMENT FOUND 3" DISK SW CORNER OF SECTION 4, T-18-N, R-14-E, TULSA COUNTY, OKLAHOMA

DEED OF DEDICATION (Book 5640, Page 958)

DEED OF DEDICATION (Book 6291, Page 1853)

RIGHT OF WAY EASEMENT (Book 4348, Page 2074)

West Kenosha Street (East 71st Street South)

SOUTH LINE SW/4 SECTION 4, T-18-N, R-14-E